

High Pressure—High Temperature, XRay Diffraction Apparatus

J. Dean Barnett and H. Tracy Hall

Citation: *Review of Scientific Instruments* **35**, 175 (1964); doi: 10.1063/1.1718773

View online: <http://dx.doi.org/10.1063/1.1718773>

View Table of Contents: <http://scitation.aip.org/content/aip/journal/rsi/35/2?ver=pdfcov>

Published by the [AIP Publishing](#)

Articles you may be interested in

[High pressure/high temperature cell for x-ray absorption and scattering techniques](#)

Rev. Sci. Instrum. **76**, 043905 (2005); 10.1063/1.1884188

[Xray diffraction of Fe at high temperatures and pressures](#)

J. Appl. Phys. **65**, 1795 (1989); 10.1063/1.342908

[Apparatus for HighPressure HighTemperature XRay Powder Diffraction Studies](#)

Rev. Sci. Instrum. **40**, 434 (1969); 10.1063/1.1683965

[Low Temperature XRay Diffraction Apparatus](#)

Rev. Sci. Instrum. **21**, 339 (1950); 10.1063/1.1745578

[A High Temperature XRay Diffraction Apparatus](#)

Rev. Sci. Instrum. **18**, 576 (1947); 10.1063/1.1741005



Discover the IQ-2000—
A new way to
INSPIRE.

Visit us at Pittcon and ACS.

 **Extrel**
Core Mass Spectrometers

time constant of the measuring network. Because of the finite length of the line, other frequencies are excited which are partially reflected by the load.

Figure 5 shows the effect of bad timing of the switches. The second spark gap was fired 170 nsec too late.

From this evidence one may conclude that it will be

possible to produce very large amounts of power in the megacycle range and for a duration of several microseconds.

ACKNOWLEDGMENT

The author is indebted to A. Lietti who conducted the experiment and made the measurements.

High Pressure-High Temperature, X-Ray Diffraction Apparatus*

J. DEAN BARNETT AND H. TRACY HALL†

Brigham Young University, Provo, Utah

(Received 29 August 1963)

A tetrahedral-anvil press has been developed that permits x-ray diffraction powder measurements at pressures to 75 kb and temperatures to 1000°C. A counting technique, rather than photographic film, is used for x-ray detection. Sample tetrahedra of compressed LiH, boron, and boron-filled plastic are used in place of the pyrophyllite customarily used for this purpose. Two possible entrance pupils are used for the x-ray beam; (1) through an anvil face, and (2) through one of the compressible gaskets. Examples of the use of this versatile apparatus for determining crystal structures (KCl, Ba, and Sn), volume compressibility (Ba), lattice-parameter changes (BN), and phase diagrams (Sn) are given.

I. INTRODUCTION

A SURVEY of procedures currently being utilized to study materials under high pressure, high temperature conditions indicates a need for developing improved techniques for obtaining more fundamental information. The relative ease with which the electrical resistance of semiconductors and metals can be measured as a function of pressure has made this the dominant procedure used to explore polymorphism, melting, etc. Such measurements, however, yield little fundamental information concerning the new phases discovered.

The use of x-ray diffraction analysis to obtain basic data is rather obvious, and attempts to use this method were discussed in the literature as early as 1933. The prime contribution of x-ray diffraction data to the field of high pressure research is in structure analysis. Since any microscopic theory of the solid-state properties of a material is structure dependent—in fact, usually structure dominated—the theoretical interpretation of most observed phenomena is ambiguous without structure data. Such data also give the most meaningful information concerning chemical bonding. In addition to the usefulness of x-ray diffraction data in structure determination, x-ray analysis must also be considered as a valuable and versatile tool for observing other solid-state phenomena. The pressure independence inherent in the diffraction process eliminates

some of the most troublesome problems encountered in pressure-dependent systems. For example, the emf of thermocouples is influenced by pressure and causes uncertainties in temperature measurements. In piston-displacement procedures for measuring volume, high pressures distort pistons and cylinders, thus causing uncertainties in determining volume changes.

At the time this work was initiated in 1959, several techniques had been developed to obtain x-ray diffraction data at moderate pressures. A review of these earlier techniques has already been given by Jamieson and Lawson.¹ Since 1960 Piermarini and Weir,² using two diamond pistons in a Bridgman anvil arrangement, have obtained x-ray photographs to 60 kb by passing the x-ray beam directly through the two anvils. Jamieson³ has obtained x-ray data at pressures in excess of 100 kb by using amorphous boron as a pressure gasket between Bridgman anvils made of cemented tungsten carbide. In this arrangement the x-ray beam passes through the gasket perpendicular to the axis of the pressure system.

Although flat-anvil techniques have several advantages, especially with respect to cost and simplicity, they suffer from three basic limitations: (1) A large pressure gradient exists over the sample region. This makes measurements in

* This work was supported by the U. S. Army Research Office, Durham, North Carolina.

† Alfred P. Sloan Research Fellow.

¹ J. C. Jamieson and A. W. Lawson, in *Modern Very High Pressure Techniques*, edited by R. H. Wentori, Jr. (Butterworths Scientific Publications Ltd., London, 1962), pp. 70–92.

² G. J. Piermarini and C. E. Wier, *J. Res. Natl. Bur. Std. A66*, 325 (1962).

³ J. C. Jamieson, *J. Appl. Phys.* **33**, 776 (1962).

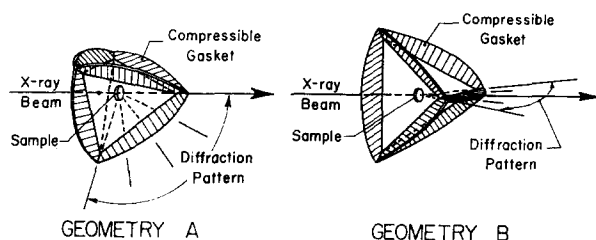

FIG. 1. Tetrahedral sample chamber showing the two possible x-ray geometries using the compressible gasket as the exit pupil.

which the pressure must be specified within a small interval difficult. (2) The uniaxial pressure produces preferred orientation among the crystallites as the sample spreads out into the thin wafer. This preferred orientation makes relative intensity measurements somewhat unreliable and hampers the interpretation of the pattern for crystal-structure determination. (3) The pressure, for a given anvil load, developed within the sample depends upon the nature of the sample since the compressibility and gasket-forming properties of each sample are different. Consequently, the apparatus calibration will be different for different sample materials. The above limitations are a consequence of the "two-dimensional" sample chamber provided by Bridgman anvils and would not be present in a system with a three-dimensional "finite" volume. A three-dimensional sample chamber with a finite volume is also the distinguishing feature of those high pressure systems possessing high temperature capabilities.

II. DESIGN CONSIDERATIONS

There are presently three types of apparatus capable of maintaining high temperature simultaneously with pressures approaching 100 kb: (1) piston-cylinder type systems variously modified for double staging or other support, (2) belt-type apparatus with its ramifications, and (3) multi-anvil devices. Of these systems, multi-anvil devices are most readily adapted to diffraction work since their compressible gaskets form in planes rather than cylinders, cones, or other such shapes. The possible arrangements of sample, electrical leads and contacts, heating elements, etc. are much greater in multi-anvil presses than in the other devices mentioned, and component assembly is usually much simpler. These features are very desirable in order to provide proper entry for the primary x-ray beam and proper exit for the diffracted rays.

During the past several years, we have developed a tetrahedral-anvil press for x-ray diffraction use. It is inherently capable of making diffraction measurements at pressures to 100 kb simultaneously with temperatures to 1000°C. In matching the x-ray geometry of the standard Debye-Scherrer powder method to the geometry of the tetrahedral-anvil press, two possibilities exist for placement of the x-ray entrance and exit pupils. These possibili-

ties are illustrated in Fig. 1. In geometry A the x-ray beam enters the chamber through a hole in the anvil face. In geometry B the x-ray beam enters through one of the gaskets. Both arrangements have been used in the present apparatus, and a discussion of their relative merits is given below.

In either of the above x-ray geometries (with 1-in. tetrahedrons), the x-ray beam must pass through from $\frac{3}{4}$ to 1 in. of the tetrahedron chamber material, including the compressible gaskets. Since x rays are being scattered by the chamber material all along the path of the direct x-ray beam, the x-ray background is abnormally high. Furthermore, the x-ray line intensities are low due to absorption and to the relatively small solid angle available for the emergence of the diffracted beam. Therefore, some method of background discrimination is necessary. The use of a counting technique as opposed to photographic film for detection of the diffracted x rays allows this discrimination in two ways: (1) A directed slit system can be used to restrict the region from which x rays enter the counter. This reduces background scattering from the chamber material. (2) The use of a pulse-height selector and a counter with proportional characteristics allows an electronic discrimination against the white radiation emanating from the x-ray tube. A counting system provides additional advantages over a film technique in that it provides for continuous observation, individual line scanning, and direct intensity measurement.

III. APPARATUS

A photograph of the apparatus is shown in Fig. 2. The tetrahedral press is of the tie-bar design, similar to the original tetrahedral press.⁴ The 600-ton capacity hydraulic rams were specially designed for this system. All parts of the press are machined to a precision consistent with an x-ray diffractometer. The position of each ram is monitored to 0.001 in. by a dial indicator, which is mechanically attached to each piston, and the four rams are maintained at equal travel for all pressures. This precaution is taken to minimize movement of the sample relative to the x-ray system. The x-ray counters are mounted on motor-driven carriages, which move on high precision geared tracks. The tracks are mounted on the tie-bars of the press to give stability. The drive motors are equipped with gear boxes to allow angular scanning rates from $\frac{1}{25}$ to 2°/min.

The important features of the apparatus, including the relationship of the two x-ray geometries as they relate to the press geometry, are shown in Fig. 3. The plane of this drawing is the plane containing the axes of two rams and the axis of the tie-bar between these rams, and is also the plane perpendicular to the opposite tie-bar. The other two rams and four tie-bars do not pass through this plane. This

⁴ H. T. Hall, Rev. Sci. Instr. **29**, 267 (1958).

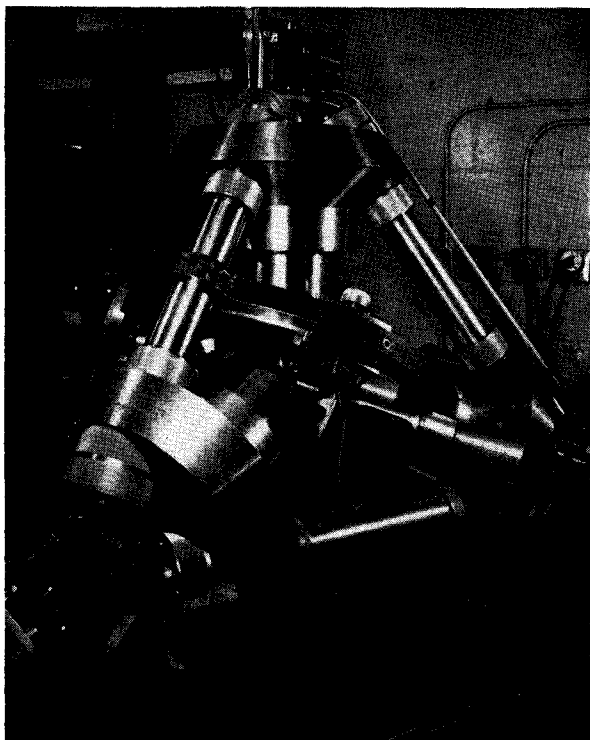

FIG. 2. Tetrahedral high pressure, high temperature x-ray diffraction apparatus.

plane also contains the compressible gasket between the anvils mounted on the two rams not shown, the x-ray tube target for both tube mountings, the scanning track, and the sample. In Fig. 3 the press parts are shown in cross section; the x-ray components are shown diagrammatically.

One of the hydraulic rams was designed with a cross axis hole to accommodate a General Electric CA-7 x-ray

diffraction tube. This tube location is designated as tube position A or mount A. The primary x-ray beam passes down the axis of the ram through a hole in the tungsten carbide anvil and impinges upon the sample. The diffracted x rays then pass out through a compressible gasket and enter the detector. A small beryllium cone is inserted into the hole of the anvil to prevent excessive extrusion of the tetrahedral cell down the hole. The detail of the sample region is shown in Fig. 4. This drawing also illustrates the use of two directed slits for background discrimination. In practice, the insertion of slit S_2 decreases the background by a factor of two or three depending upon the size of the slit and the sample under study. In order to increase the solid angle available for the diffracted rays, the binding rings and the anvils were beveled in the area beyond the gasket region to allow a 4° divergence as indicated in Fig. 4.

Each of the two x-ray geometries discussed above is applicable to specific types of investigations and has advantages distinct from the other. The available 2θ angle for mount A is 0 to 110° and for mount B is -55 to $+55^\circ$. Thus, more of a given pattern is available with mount A, but greater accuracy can be obtained with mount B since both sides of the direct beam are available. When mount A is used, the x-ray beam passes through less material than when mount B is used. Three separate patterns are simultaneously available with mount A since each of the three gaskets meeting at the apex of the tetrahedral chamber opposite the x-ray ram can serve as an equivalent exit for the diffracted beam. The apparatus, as now constructed, is equipped with three separate scanning tracks, counters, and electronic systems—each measuring x rays being diffracted through one of these gaskets. Obtaining

FIG. 3. Cross section of the apparatus showing the x-ray tube mounted in each position and the detector scanning mechanism as they relate to the high pressure system, (1) tiebar, (2) hydraulic oil, (3) ram base, (4) piston assembly, (5) x-ray tube and collimator in position B, (6) x-ray tube and collimator in position A, (7) undeviated x-ray beam, position A, (8) undeviated x-ray beam, position B, (9) diffraction angle (2θ), position A, (10) diffraction angle (2θ), position B, (11) sample, (12) scintillation counter and pre-amp, (13) scanning motor, (14) scanning carriage and track.

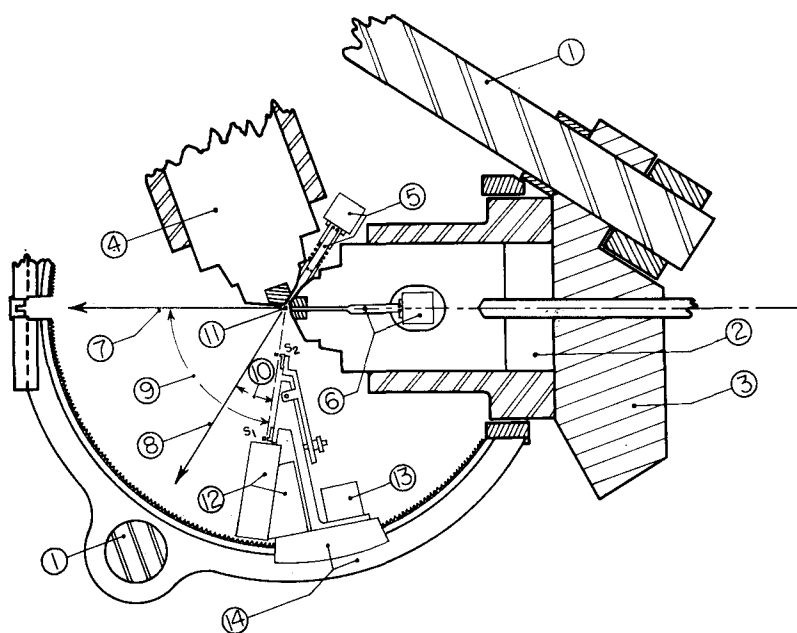

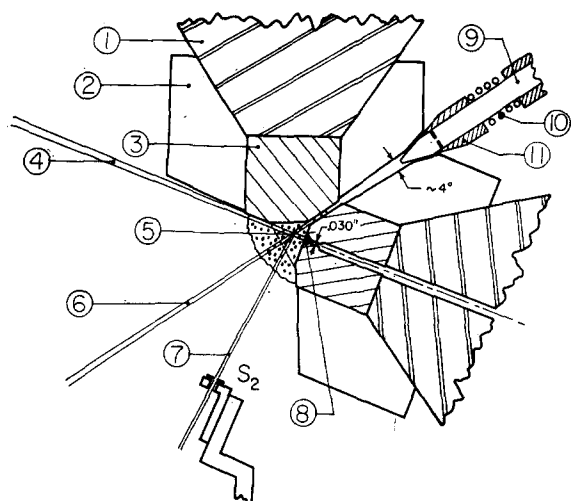

FIG. 4. Detail of the sample-chamber region and x-ray collimator for x-ray tube position B. Background discrimination by use of detector slit system is illustrated. (1) cemented tungsten-carbide anvil support, (2) steel anvil binding ring, (3) carbide tetrahedral anvil, (4) region of undeviated x-ray beam, position A, (5) sample, (6) region of undeviated x-ray beam, position B, (7) region viewed by detector slits, (8) beryllium cone, (9) x-ray slit collimator, (10) spring, (11) collimator positioner.

three separate diffraction patterns increases reliability and also gives added versatility to the apparatus by making possible the simultaneous observation of three different points in the intensity pattern.

During the design of the apparatus the authors were concerned about the effect of the hole in the carbide anvil upon anvil lifetime. During more than 100 pressure excursions, many of which were 10–20 h in duration at pressures between 60 and 70 kb, there has been no evidence of preferential breakage of this anvil. Actually, the only breakage experienced with any of the anvils has occurred during instances of gasket blowout.

The x-ray counting system is the standard XRD-5 detection system accompanying the General Electric x-ray diffractometer. The proportional properties of the scintillation counter coupled with its high efficiency for Mo $K\alpha$ radiation make its use advantageous. The electronic preamplifier is attached to the carriage along with the counter in a modified housing. The output of the preamplifier goes to the amplifier mounted under the press and then to the pulse-height selector and scalar mounted in an auxiliary rack. Each counting system is equipped with a digital printer which permits the analysis of very weak intensity patterns.

Probably the most difficult problem encountered in high pressure x-ray research involves the selection of a material for the pressure chamber that, in addition to transmitting the pressure, is relatively transparent to x rays. Much of the earlier x-ray work at high pressures used beryllium "bombs," diamond "bombs," or diamond anvils. The authors had made preliminary measurements on amorphous boron powder before the present work was initiated,

but it soon became apparent that the high internal friction of amorphous boron would not allow adequate gasket extrusion to occur in the tetrahedral-anvil press. An investigation of the frictional properties of a number of low Z compounds led to the use of LiH as a pressure cell.

LiH tetrahedra one inch on an edge are formed in a specially designed compression molding die at approximately 80 000 psi from small crystals approximately 1 mm in mean dimension. (Boron and other tetrahedra are similarly formed.) Samples in LiH tetrahedra have been studied to approximately 55 kb. The internal friction of LiH is lower than pyrophyllite, and an excessive amount of extrusion takes place at the higher pressures, thus limiting its usable pressure range. A study of intimate mixtures of LiH and amorphous boron reveals internal friction and pressure transmitting properties ranging between the two materials. Pressures to 75 kb have been maintained for several hours in both 50-50 and 25-75 wt% LiH-B tetrahedra. Higher pressures have not yet been attempted. The hygroscopic nature of LiH and the abrasive nature of B powder complicate the use of these materials in sample chambers, since fabrication and machining of pure LiH or B tetrahedra and of tetrahedra composed of B-LiH mixtures are difficult. The use of amorphous boron as a filler in phenolic thermo-setting plastic of low x-ray absorption has been investigated. The pure plastic resin "explodes" when subjected to pressures in a gasket-forming device. The boron inhibits this explosion and also increases the frictional properties of the plastic. Tetrahedra containing both 40 and 50 wt% boron filler have been used successfully to obtain the 59 kb barium transition by x-ray analysis, but the tetrahedra frequently "explode" at higher pressures. The plastic resin is obtained from Hooker Chemical Company and is designated as Durez 14684. Tetrahedra are formed by compression molding in a specially designed mold placed in a standard metallurgical sample mounting press.

The x-ray sample is prepared according to standard procedures to provide randomly oriented polycrystals of 5–50 μ average dimensions. Sometimes it is appropriate to dilute a high Z material by intimately mixing its powder with the powder of a low Z substance. The latter substance should have low internal friction in order to transmit pressure effectively to the powder under study. Polyethylene and hexagonal BN have been used for this purpose. In the transmission x-ray geometry used here, the sample thickness is set at approximately one absorption length in order to optimize the diffracted intensities. There are many possible ways in which the sample, the heating element, and other components may be arranged within the tetrahedral cell. We have often used the sample in the form of a thin wafer or metal sheet and, for temperatures below 400°C, sandwiched it between two pieces of polyethylene to implement hydrostatic conditions. The poly-

ethylene produces a somewhat diffuse low angle diffraction pattern which can easily be distinguished from the sharper lines characteristic of inorganic structures. For higher temperatures the polyethylene has been replaced with BN or the pure plastic resin. Both metal and graphite heater elements have been used. The metal heaters are placed so as not to obstruct the x-ray passage. However, the x-ray beam will penetrate a graphite heater without prohibitive intensity loss, thus allowing greater freedom in sample-heater construction.

IV. PRESSURE CALIBRATION

The pressure system has been calibrated in the usual manner by utilizing resistance transitions in Bi, Yb, and Ba as fixed points. Following the present trend among high pressure workers, the values of 25.3 kb for the bismuth I-II transition and 59 kb for the barium transition have been used. The value of 39.5 kb for the Yb transition is taken from the work of Hall and Merrill.⁶ Since the sample geometry used in determining a resistance calibration point is similar to the geometry used for x-ray measurements when the x-ray tube is in position B, a simultaneous measurement of the x-ray diffraction pattern and electrical resistance can be made. In the case of Yb and Ba the resistance transitions and crystal-structure change were observed to take place concurrently, thus establishing the identity of the two phenomena. Since the analysis of the x-ray pattern in each case defines the volume, these observations represent the first experimental proof of the identity of Bridgman's volume and resistance transitions in Ba and Yb. The crystal structure transition is observed by placing the counter at the angle of an intense peak of the x-ray pattern and recording the peak intensity as a function of pressure. In the cases observed so far, the diffraction intensities decrease at a faster rate than the resistance changes. Since the x-ray beam "sees" only a small portion of the resistance sample, this time variation indicates that the phase change reaction does not occur uniformly throughout the sample.

The calibration curve for the tetrahedral press is different, as might be expected, when different materials are used for the tetrahedral pressure cell. Calibration curves for pyrophyllite, 50-50 wt% B-LiH, 50 wt% boron filled plastic, pure LiH, and LiH coated with boron powder are given in Fig. 5. The sample in each case is imbedded in polyethylene, similar to an x-ray sample. The barium transition using a boron coated LiH tetrahedron was actually not obtained, but comparison of compressibility measurements on the barium sample with those obtained in other pressure chambers establish the point marked Ba on that curve. As an indication of the pressure transmitting properties of various B-LiH mixtures and various amounts

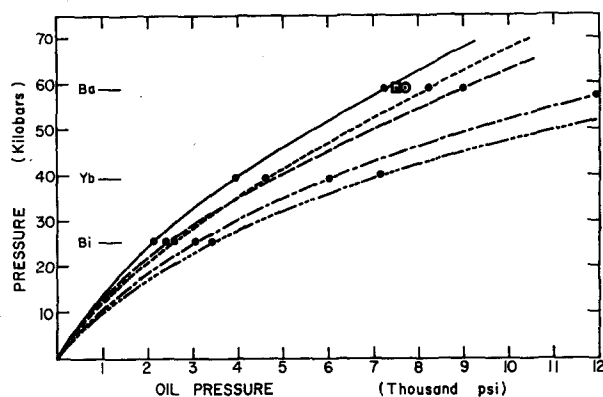

FIG. 5. Pressure calibration curves for the tetrahedral press using sample chambers of various x-ray transparent materials (anvils $\frac{1}{4}$ in. on an edge, tetrahedron approximately 1 in. on an edge). Sample surrounded by polyethylene. — Pyrophyllite; - - - 50 wt% boron-filled plastic; - · - · 50-50 wt% boron-LiH; · · · · LiH coated with boron; - - - - LiH; □ 75-25 wt% boron-LiH; ○ 40 wt% boron filled plastic.

of boron filler in the plastic tetrahedron, two other calibration points are placed on the graph of Fig. 5. The variations indicated by these additional points must be considered as only qualitative.

Since the position of a single diffraction line determines the relative volume of a cubic sample, a compressibility curve for a cubic material can be obtained in a reasonable amount of time. Such a procedure could provide a functional calibrating relationship rather than a calibration based on fixed points. Exploratory work for establishing a calibration procedure utilizing Bridgman's compression data for NaCl has been initiated. Preliminary experiments show consistency at the fixed points and also inject the curvature into the calibration curve necessary to pass through the origin.

V. CAPABILITIES OF THE APPARATUS

The value of the high pressure, high temperature x-ray diffraction apparatus described above stems from its great versatility. A few of the possible techniques that have been explored and the type of measurements of which the apparatus is capable are discussed below. The data included here are given only to illustrate the use of the apparatus and are not intended to report new experimental facts in final form.

A. Crystal-Structure Determination

During the second excursion to high pressure after the x-ray system was placed in operation, a study of KCl was made. The diffraction pattern was recorded on a strip-chart recorder at several pressures below and above the volume transition reported by Bridgman at 20 kb. Representative patterns of a series of ten patterns recorded during a period of 8 h are reproduced in Fig. 6. Each trace required approximately 30 min to record, but the patterns

⁶ H. T. Hall and L. Merrill, *Inorg. Chem.* **2**, 618 (1963).

tus. The absolute accuracy is approximately one half this value, due to uncertainty in the sample position.

B. Temperature Capabilities

The inherent temperature capabilities of the x-ray apparatus are the same as the tetrahedral anvil press. Present work has been generally limited to temperatures below 500°C, although some exploratory work has been carried out to 1000°C. Extension to higher temperatures appears feasible for at least some studies, and work in this direction will be carried out when the need arises.

The limiting factors in temperature attainment are the properties of the x-ray transparent sample-chamber material. The active nature of LiH at high temperatures and its low melting temperature (682°C at one bar) restrict its use. Boron-filled plastic tetrahedra have been used in all temperature work to date. Our limited experience at the higher temperatures indicates that 1000°C represents a practical limit for the plastic used. Mixtures of boron and BN powders formed into tetrahedra show promise for use at higher temperatures. Structure-determination studies at high temperature and high pressure are carried out in precisely the same manner as discussed above. Care is taken in sample preparation to avoid obstruction of the x-ray beam by the thermocouple, heaters, or electrical connections. The temperature is maintained and monitored throughout the x-ray scan that may last several hours. The structure of tin II at 39 kb and 314°C has been determined using the apparatus. The structure consists of single atoms placed at each point of a body-centered tetragonal lattice with $a = 3.81 \text{ \AA}$ and $c = 3.48 \text{ \AA}$.

In addition to structure analysis, the x-ray apparatus is a powerful tool for detecting and studying phase changes. As an example of such a study, the melting curve of tin first reported by Dudley and Hall⁶ was investigated to 45 kb, and the tin I-II phase line was followed from the 34 kb cusp in the melting curve to 75 kb. A comparison of this work with previous workers is shown in Fig. 8. Melting was detected by the disappearance of the (200) and (101) lines of tin I (ordinary white tin) below 34 kb and by the disappearance of the (110) and (101) lines of tin II above 34 kb. Detection of melting by this technique is defined to within a few degrees Centigrade depending upon the intensity of the peak being observed. Errors greater than this can result from improper location of the thermocouple bead and from temperature gradients within the tetrahedron chamber. The tin I-II phase change was observed by the disappearance of the (200) and (101) lines of tin I and the appearance of (110) and (101) lines of tin II. This transformation takes place in a few seconds, and the phase change is reversible within a range of less than 2°C.

⁶ J. D. Dudley and H. T. Hall, *Phys. Rev.* **118**, 1211 (1960).

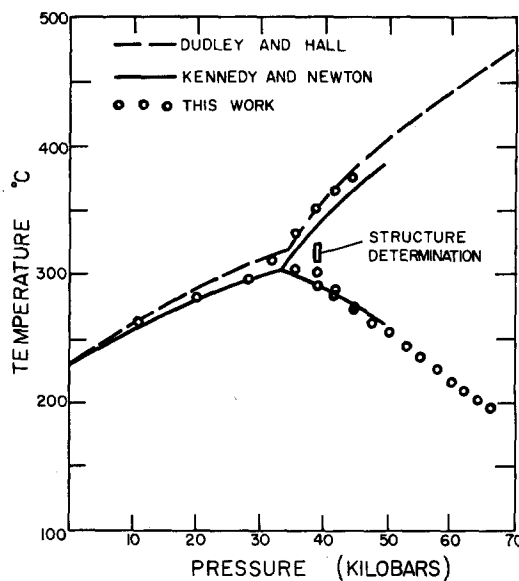

FIG. 8. Phase diagram of tin as measured by x-ray diffraction techniques.

Again the versatility of a counting technique is evident in the above mentioned phase studies. If adequate x-ray intensities are available, as was the case in some of the tin studies, several points on a phase line or melting curve can be measured in an hour. The addition of the time variable to the observation of polymorphism gives information not otherwise attainable. Furthermore, the short time interval between occurrence, observation, and evaluation of the phenomena allows one to direct the progress of a study in a more effective manner and to obtain a conceptual "feel" for the kinetics of the phenomena not afforded when the time element is not present.

Due to the relatively long scanning time required for a structure determination, the temperature attainable is lower than that for phase diagram studies. Excursions to high temperatures for 2–5 min may well be adequate to determine phase lines and melting curves; however, high temperatures must be maintained for several hours to make a structure analysis.

C. Thermodynamic Data

The x-ray attachment to the tetrahedral anvil apparatus makes available, for the first time, an instrument capable of making volume measurements simultaneous with the attainment of pressures up to 100 kb and temperatures to 1000°C. A relatively large new thermodynamic region now becomes available for such studies, and the possibility of confirming theoretical equations of state for solids or of obtaining empirical relationships becomes evident. Preliminary studies have been made to confirm the capabilities of the apparatus, but adequate time has not been available to undertake a measurement over the complete range of pressure and temperature for any sample.

Compressibility and thermal expansion measurements by x-ray techniques require a relatively high degree of accuracy since the analysis yields a volume rather than a change in volume. Furthermore, relative accuracy is lost in computing volume from linear dimensions. As an illustration of the apparatus capabilities, the compressibility of barium was measured to 60 kb and compared with Bridgman's data (see Fig. 9). The problem of pressure calibration at elevated temperatures became evident during preliminary studies of thermal expansion at high pressures, and further investigation was felt necessary before reporting any data.

For low symmetry crystal systems, x rays detect, in addition to the microscopic PVT data, changes in unit cell dimensions which shed light on the single-crystal elastic constants at high pressures. We have observed, for example, the different compressibilities along the a and c axes of hexagonal NaNO_3 and hexagonal BN. For BN the percentage change in the lattice parameters, the c/a ratio, and the resulting compressibility curve as shown in Fig. 10. The work by Kabalkina and Vereshchagin⁷ to 17 kb is shown for comparison.

D. Miscellaneous Techniques

The fundamental nature of the x-ray diffraction process and its lack of dependence on external influences provide a

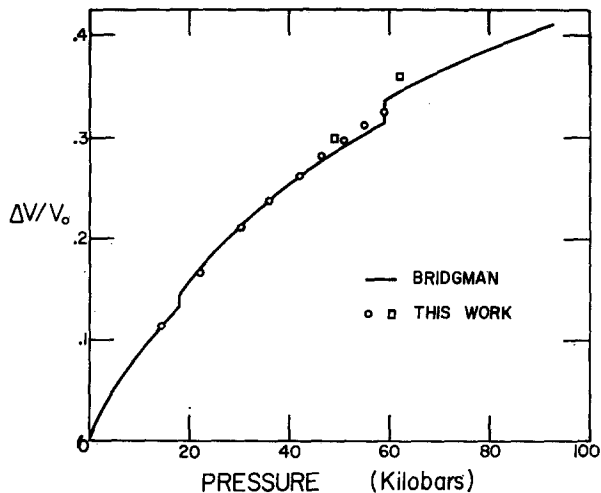

FIG. 9. Compressibility of Ba to 60 kb. \circ : determined using geometry A. \square : determined using geometry B yielding greater accuracy.

⁷ S. S. Kabalkina and L. F. Vereshchagin, Doklady Akad. Nauk SSSR **134**, 330 (1960) [English transl.: Soviet Phys.—Doklady **5**, 1065 (1961)].

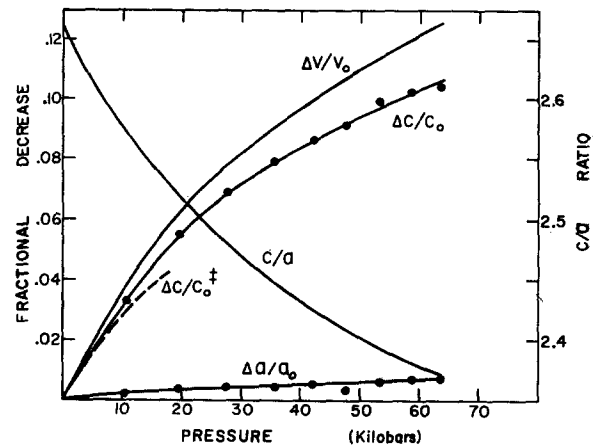

FIG. 10. Lattice parameters of hexagonal BN as a function of pressure to 70 kb. The dashed curve is data reported by Kabalkina and Vereshchagin (See Ref. 7).

technique for investigating several high pressure phenomena in a manner not previously available. The simultaneous observation of two phases of one material as indicated for KCl in Fig. 6 is one illustration. Similarly one can simultaneously observe two different substances in intimate contact, thus assuring equal pressures. Such a technique should be useful in pressure and temperature calibration studies.

Since a one-to-one correspondence must be assumed between the atomic separation and pressure in a given phase, x-ray diffraction measurements also provide a method of separating the true sample hysteresis from apparatus hysteresis during decrease of pressure. Furthermore, if a calibrating substance of known compressibility is mixed with the sample, the pressure is known at any time after numerous applications and reversals of pressure and temperature. Such studies may be useful in learning more about the operation of the tetrahedral press itself. Limited observations of this nature have been made.

The possibility of observing the onset of a chemical reaction as well as measuring reaction rates is evident. The use of two independent counters in such a study would have great advantages. Experiments of this nature have not yet been conducted.

VI. ACKNOWLEDGMENTS

The authors express their thanks to the following graduate students for their assistance in carrying out various phases of the work: Gordon Bethers, Leo Merrill, Roy Bennion, Vern Bean, and Rondo Jeffery.