

An Optical Fluorescence System for Quantitative Pressure Measurement in the DiamondAnvil Cell

J. D. Barnett, S. Block, and G. J. Piermarini

Citation: [Review of Scientific Instruments](#) **44**, 1 (1973); doi: 10.1063/1.1685943

View online: <http://dx.doi.org/10.1063/1.1685943>

View Table of Contents: <http://scitation.aip.org/content/aip/journal/rsi/44/1?ver=pdfcov>

Published by the [AIP Publishing](#)

Articles you may be interested in

[High-pressure spectroscopic measurement on diffusion with a diamond-anvil cell](#)

Rev. Sci. Instrum. **74**, 2472 (2003); 10.1063/1.1556955

[Precise magnetization measurements under high pressures in the diamondanvil cell](#)

Rev. Sci. Instrum. **66**, 3307 (1995); 10.1063/1.1145499

[Lowtemperature, highpressure optical system with a compact diamondanvil cell and a closedcycle refrigerator](#)

Rev. Sci. Instrum. **57**, 2992 (1986); 10.1063/1.1138980

[Pressure–volume measurements by using diamondanvil cells and an image processing system](#)

Rev. Sci. Instrum. **57**, 500 (1986); 10.1063/1.1138918

[Optical length determinations in the diamondanvil cell](#)

Rev. Sci. Instrum. **55**, 558 (1984); 10.1063/1.1137791



Discover the IQ-2000—
A new way to
INSPIRE.

Visit us at Pittcon and ACS.

 **Extrel**
Core Mass Spectrometers

THE REVIEW OF SCIENTIFIC INSTRUMENTS

VOLUME 44, NUMBER 1

JANUARY 1973

An Optical Fluorescence System for Quantitative Pressure Measurement in the Diamond-Anvil Cell

J. D. Barnett *, S. Block, and G. J. Piermarini

Institute for Materials Research, National Bureau of Standards, Washington, D.C. 20234

(Received 5 September 1972; and in final form, 10 October 1972)

An optical system for rapid routine pressure measurement is described which utilizes a pressure shift in the sharp *R*-line fluorescence spectrum of ruby or similar materials. The system, which consists of a standard polarizing microscope and a 1/4 m monochromator with associated photodetection system, is used with the diamond-anvil pressure cell, but can be employed with suitable modification in any pressure system which has optical access. The precision of the pressure measurement in a hydrostatic environment up to 100 kilobar is 0.5 kilobar using ruby as the pressure sensor. This precision is better than the accuracy of the present pressure scale above 40 kilobar. The merits of fluorescent materials other than ruby as pressure sensors are also discussed. A description of a Waspaloy diamond cell with some modifications in design is given. This improved cell and associated techniques extends the pressure range in gasketed systems up to 200 kilobar at room temperature and to moderate pressures at 700° C.

INTRODUCTION

The diamond-anvil pressure cell developed in this laboratory¹ has been used extensively during the past twelve years for visual observation of pressure effects on materials including polymorphic transformations and optical effects with polarized light,² for optical absorption measurements,³ and for x-ray diffraction measurements on both polycrystalline,⁴ and single crystal materials.^{5,6} The original design has been modified and refined in this and several other laboratories, and has been specialized for specific experiments. Originally, the diamond cell was used to study polycrystalline materials where the sample itself provided the gasket seal. Later, the pressure cell was used with a metal gasket so that liquids could be contained in the cell. Liquid samples have been studied as well as single crystal specimens contained in a liquid environment.

The gasketed approach provides a truly hydrostatic condition below the freezing pressure of the contained liquid, but pressure gradients develop above this point. Results using this method have been reported to only moderate pressures (<40 kilobar). The nongasketed technique has been extended to pressures of 300 kilobar^{7,8}; however, the pressure gradients are often severe, and measurements are

restricted to polycrystalline samples. Solid samples can also be enclosed in a metal gasket and the resulting pressure gradients are much less than when no gasket is used.

In most of the earlier work with the diamond cell, pressures were estimated from applied load. Such estimates yield an average pressure over the sample in the nongasketed technique, but are even less reliable using a gasketed sample, since the gasket absorbs an unknown amount of the load. One approach to pressure measurement in the cell is based upon the shift of an optical absorption band in nickel dimethylglyoxime.³ This technique has not gained general acceptance due to the limited temperature stability of nickel dimethylglyoxime, interference with measurements on materials under study, and the complexity of the measuring apparatus. Pressure measurement utilizing the change in lattice constant of known materials, notably NaCl, has been used extensively by workers using the cell in x-ray powder studies.^{7,8} Those using the cell for phase-equilibrium studies or optical observations have not used the lattice-constants approach due to the excessive time (up to 300 h) involved in the x-ray measurement. The lack of a rapid pressure measurement has seriously hampered research using the diamond cell, since one cannot prescribe and then produce a desired pressure condition

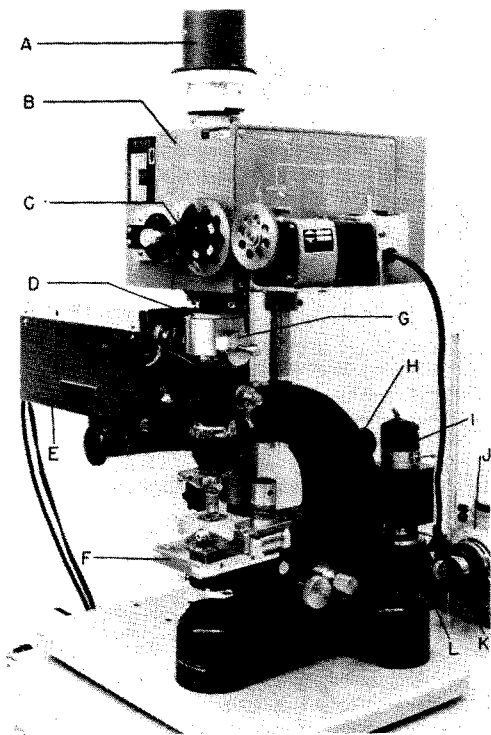

FIG. 1. A photograph of the basic pressure measuring system. The essential features and components are identified with letters which are referred to in the text.

and thus cannot give meaningful *in situ* direction to an experimental study.

From this laboratory we recently published a preliminary report on a pressure-measuring technique using the shift of the *R*-line fluorescence in ruby.⁹ A small fragment of ruby or other sharp-line fluorescing material is placed within the pressure chamber along with the sample, fluorescence is excited by high-intensity light, and the fluorescent emission spectrum is recorded. In ruby the wavelength shift of the *R*-lines with pressure was shown to be approximately linear. In this paper we report the details of a convenient system designed for use as a precise, rapid, routine instrument for pressure measurement using this fluorescence technique. The system has been in use for several months and consists of a high-resolution, high dispersion optical monochromator attached to a research polarizing microscope with appropriate light sources, filters, and mirrors. We also report some details of recent modifications in pressure-cell design and technique which permit studies in gasketed systems to temperatures of 700°C at moderate pressures and to pressures of 200 kilobar at room temperature.

I. DESCRIPTION OF THE SYSTEM

A labeled photograph of the basic system is shown in Fig. 1. The microscope is of rugged construction and supports the weight of the $\frac{1}{4}$ m monochromator (B) and

associated photodetector (A). Appropriate adjusting screws are provided which allow precise positioning of the monochromator relative to the microscope. The optical system is thus mechanically unified, and the critical optical alignment is readily made and permanently maintained. The high pressure mercury light source (J) is placed at the rear of the microscope for convenience. The source is normally positioned as shown for transmission illumination, but can be positioned at H in Fig. 1 for epi-illumination. The epi-illumination has not been used extensively, but allows measurements when studying optically opaque samples, provided the fluorescent pressure sensor can be located in the pressure chamber next to the top diamond anvil. To visually study the sample using polarized light in the normal manner, a standard tungsten microscope-illumination lamp (I) is provided at the rear of the microscope and can be optically inserted in place of the high intensity mercury lamp by means of a movable mirror located at L.

The pressure cell (F) is attached firmly with clamping screws to the movable microscope stage such that coarse horizontal positioning of the cell in two dimensions can be made before clamping, and focusing is accomplished by moving the stage vertically. Fine horizontal alignment of the sample in the cell with the optical axis of the system of the microscope is made by utilizing a movable objective on the microscope. For high temperature studies the pressure cell is thermally insulated from the microscope stage.

Light filters are placed in the optical path at positions K and D. The filter at position K removes from the exciting source light which has wavelengths in the spectral region near the fluorescent light wavelength thus preventing masking of the fluorescence. The filter located at D passes only light with wavelengths in the region of the fluorescent wavelength and thus reduces multiple-scattered light background and undesired overlapping orders in the monochromator.

The television camera (E) and monitor (not shown) are built into the system to eliminate eye fatigue during extended experiments involving visually observed phase changes and to allow simultaneous viewing of the sample by more than one individual. It is not uncommon for phase changes to take place in seconds following a temperature stabilization of many minutes, and the constant visual concentration on microscopic detail over the periods involved causes serious eye fatigue. The quality of the television image is not totally comparable to direct viewing but has been very satisfactory in most instances. Television image quality is improved by using filtered light from the mercury source through a small diaphragm aperture rather than the conventional tungsten illuminator. The light image is transmitted to the television camera by inserting a movable mirror indicated at G. The television camera is mounted on an auxiliary support.

After the emitted radiation is dispersed by the monochromator, the resulting "monochromatic" light enters the photodetector, and the intensity is measured and recorded as a function of wavelength by a picoammeter and strip chart recorder (both not shown). The special optical features of the monochromator are discussed later. The wavelength drive shaft (C) of the monochromator is rotated by a multispeed gear motor with six available speeds. An auxiliary vernier dial has been placed on the wavelength drive gear, as seen in the photograph, to enhance measurement sensitivity. The gear motor can be conveniently disengaged to allow manual searching. Higher precision in the pressure measurement is obtained with lower scanning speed. Manual adjustment to peak maximum yields precision of from 2 to 3 kilobars. The speed typically used requires less than 5 min for a pressure measurement and yields precision of less than 1 kilobar.

II. FLUORESCENCE SPECTRA CHARACTERISTICS

We discuss here some pertinent characteristics of sharp-line fluorescence for two reasons: (1) The design requirements for the monochromator and other optical components are determined by the spectrum to be studied. (2) Criteria must be established for selecting optimum fluorescing materials for specific applications. The following spectrum characteristics are considered significant: (a) spectral-line intensity (intensity per unit volume of fluorescent material); (b) pressure coefficient $d\lambda/dP$; (c) temperature coefficient $d\lambda/dT$; (d) spectral linewidth $\Delta\lambda_w$ (FWHM); (e) wavelength λ ; (f) singlet, doublet, or multiplet lines; (g) low or high continuum background.

An ideal spectrum for this application is a singlet line

with a high intensity, a large pressure coefficient, a small linewidth, a small temperature coefficient, and little or no surrounding background. These characteristics should remain even at high temperatures. The specific intensity is of importance since it determines the minimum size fragment required for observation. One might expect very low intensities due to the small size crystal usable in the pressure chamber of the diamond cell. The line intensities of all materials thus far investigated decrease drastically and the linewidths increase with temperature, and these effects limit their use at higher temperatures. The intensity is roughly proportional to impurity (dopant) concentration at lower concentrations, but multiple interactions between impurity sites become increasingly significant at higher concentrations.¹⁰

In Table I we show a comparison of a few materials tested for possible use as a pressure sensor. Ruby has the highest intensity per unit volume at room temperature by factors of from 5 to 100. The pressure coefficient for ruby is approximately $+0.365 \text{ \AA/kilobar}$, while values between -0.13 and $+0.84 \text{ \AA/kilobar}$ have been measured on other selected materials as shown. Spectral line half-width for ruby is $\approx 6 \text{ \AA}$ at room temperature, but varies from less than 0.1 \AA below 50 K to greater than 15 \AA above 370°C .¹¹ All other materials measured have larger half-widths than ruby at room temperature. In general, those materials exhibiting large pressure coefficients also exhibit large temperature coefficients. The line broadening causes the R_1 and R_2 lines to overlap with increased temperature and limits the use of the individual R -lines for pressure calibration to less than 200°C . However, the composite line can be used with decreased precision to 400°C . In the extended temperature range to 300°C the precision can be improved

TABLE I. Characteristics of selected fluorescence spectra considered for use as a pressure indicator.

Material ^a	Line designation and description	Wavelength (\AA)	Relative intensity	$d\lambda/dP^b$ (\AA/kilobar)	$d\lambda/dT^b$ ($\text{\AA}/^\circ\text{C}$)	Linewidth ^c (\AA)	Background ratio I_b/I_p
Ruby (Al_2O_3) (0.5% Cr)	R -lines	6928	very strong	0.36	0.068	7.5	0.01
	Doublet	6942	strong				
YAlO_3 (0.2% Cr)	R -lines	7228	strong	0.70	0.076	10	0.28
	Doublet	7251					
YAG ^d (0.38% Cr_2O_3)	R -lines	6887	medium	0.31	0.105	8	0.53
	Doublet	6878					
YAlO_3 (2.5% Cr)	Pair line	7320	strong	0.84	0.093	21	0.39
	Singlet						
MgO (Cr unknown %)	R -line	6992	weak	0.35	0.09	10	0.92
	Singlet						
YAlO_3 (Nd unknown %)	R_2 - Z_2 line ^f Multiplet	8753	strong	-0.13	0.010	20	0.22

^a Amount of dopant is designated as a weight percent.

^b These values were measured and are recorded here for comparison purposes only and are not reported as accurate measurements of the derivatives with respect to pressure and temperature. We consider the values to be accurate to approximately 10%.

^c Linewidths indicated are those measured with the apparatus described herein. They represent full width at half-maximum values (FWHM).

^d Ratio of background intensity near the peak to intensity of the peak above background. In MgO and the Nd-doped YAlO_3 samples the background may be due to poor crystal quality and/or other impurities.

^e Yttrium aluminum garnet.

^f As designated by Weber and Varitimos,¹⁸ ${}^4F_{3/2}$ - ${}^4I_{9/2}$.

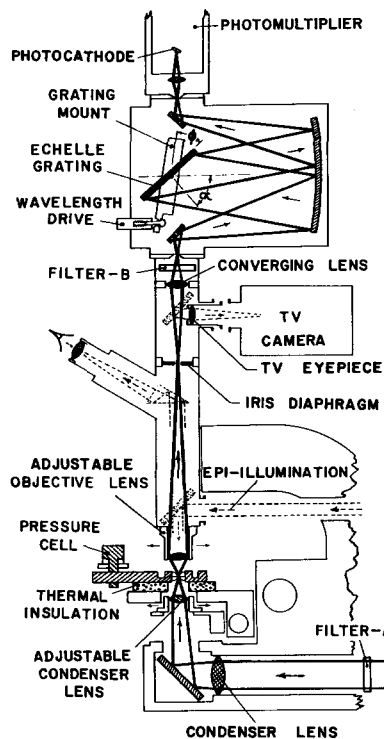

FIG. 2. Schematic diagram of the optical features of the pressure measuring system.

by deconvoluting the overlapping peaks by such methods as Fourier analysis. However, above 300°C the peaks merge and cannot be separated into components and the composite line must be used. The use of a material with a single line would avoid this problem. Many fluorescent materials exhibit a high continuum light level in the region around the sharp fluorescent lines, and this background increases with increased temperatures. It should be noted that the intensity designation in Table I is only qualitative since no control was exercised over sample size. The reported values are not integrated intensities, but refer to peak height-to-background ratios. All the substances tested fluoresce in the far red or near infrared near the ruby *R*-lines. From the comparative data shown in Table I, it is obvious that ruby has overall good characteristics compared with other materials. When comparing materials for greatest precision in pressure, the ratio of the pressure coefficient to the line width is a good figure of merit. Since this ratio is 50% higher for the YAlO_3 *R*-line than for ruby, YAlO_3 may be of specialized use if higher precision is desired and low intensity is not a problem. This is true, for example, at moderate pressures and temperatures.

The following materials were also considered but discarded due to high background or low intensity in the 1 bar, room temperature spectrum: emerald, Al_2O_3 (V_2O_5 doped), Al_2O_3 (MnO_2 doped), MnF_2 (Sm doped), spinel (Cr doped), CdF_2 (Er doped), and CdF_2 (Eu doped).

III. OPTICAL SYSTEM

The characteristics of the fluorescence spectra discussed in Sec. II indicate a requirement of less than 5 Å resolution for the monochromator to preserve the natural linewidth of the measured fluorescence. The magnitude of the line shifts with pressure requires the use of high optical dispersion to improve precision in the pressure measurement. This reproducibility is limited ultimately by the mechanical precision and stability of the slits, grating wavelength drive, and other mechanical features of the monochromator. To optimize the magnitude of the measured signals, the light-gathering ability of the system is important and, as might be expected, requires a fast monochromator (small f/number).

The light-gathering properties of the microscope are very good, but care must be exercised to preserve this feature in the monochromator while maintaining the required resolution. The microscope provides a relatively large image (approximately 6 mm in diam) with a very small optical divergence. Resolution in the monochromator requires a small entrance slit through which the light from the microscope must pass. A converging lens is thus inserted in the upper part of the microscope tube to reduce the light beam diameter to match the slits of the monochromator. This converging lens also drastically increases the divergence of the beam and makes necessary the small f/number . As a consequence, use of a high-dispersion monochromator has an additional advantage because less convergence of the microscope beam is required to maintain a particular resolution within the monochromator.

Preliminary estimates of an optimum light-gathering system utilizing an $f/3.5$ monochromator with 5 Å resolution yield a desired reciprocal linear dispersion of approximately 7 Å/mm when using a typical high pressure sample with the usual 20× objective. Monochromators using standard gratings with dispersions of this magnitude are typically 1 m focal-length instruments and are large, relatively expensive, and difficult to build with small $f/\text{numbers}$. The desirability of high dispersion in a small, inexpensive, and convenient instrument, and the fact that measurements are to be made in a preselected, restricted, spectral range suggest the use of an echelle grating used in high order as the dispersing element of the monochromator. A $\frac{1}{4}$ m monochromator using an echelle grating (300 grooves/mm) provides reciprocal dispersions as small as 3 Å/mm for wavelengths near 4000 Å in the fourteenth order. We normally use the echelle near 7000 Å in the eighth order and obtain a reciprocal dispersion of approximately 8 Å/mm.

The optical system is shown diagrammatically in Fig. 2. It consists of (1) two filters, (2) a light-condensing system, (3) the microscope optical system itself, (4) a diaphragm for isolating specific regions of the sample, (5) the con-

verging lens preceding the monochromator, (6) the monochromator including the echelle grating, and (7) the photodetector. Each feature will now be discussed in turn.

When using ruby or any other material which fluoresces in the far red, filter A is designed to remove all of the red and infrared radiation. A saturated aqueous solution of $\text{CuSO}_4 \cdot 5\text{H}_2\text{O}$ 1 cm thick or a Schott BG-18 with a water heat shield have been used. Filter B is a far red transmitting filter such as a Schott RG-665. Filters A and B would have to be reselected if other wavelengths were being studied.

The condensing lenses are designed to concentrate the maximum exciting light on the sample. The adjustable condensing lens is positioned horizontally and focused vertically to maximize the recorded signal in the photo detector. When using a 200 W mercury light source and this condensing system, one can cause significant undesirable heating of a ruby specimen in air. During experiments the improved thermal dissipation into the pressure system allows one to use more light without noticeable heating effects. Temperature increases of several degrees in the diamond cell have been observed, however, at our maximum light level, therefore care must be exercised.

For proper optical alignment of the microscope tube, the sample, the objective lens, the diaphragm, the slits of the monochromator, and the cross hairs in the binocular eyepiece should all lie on a single optical axis. Since the sample is under pressure and the pressure cell must be held relatively rigid as pressure is changed, it is not convenient to position the sample precisely. We have thus used a movable objective lens. The diaphragm and the monochromator are permanently positioned in the microscope tube along the optical axis defined by the cross hairs in the eyepiece. With this arrangement, light emitted from any crystal which appears at the cross hairs of the eyepiece will pass through the center of the diaphragm and be analyzed in the monochromator when the beam is transferred from the binocular to the vertical tube. In practice the objective lens, which is initially positioned on a prescribed optic axis, is used only as a fine adjustment to place a desired feature of the sample at the cross hairs or to maximize intensity. When this condition is met, the light beam can be transferred from the binocular to the vertical tube of the microscope and will thus be analyzed. Since the diaphragm, the monochromator slit, and the cross hairs are all conjugate foci in the upper end of the microscope, they remain very nearly aligned with each other even though the objective lens is moved slightly.

When using the diaphragm to isolate specific areas of the sample, the microscope must be refocused to place the image in the plane of the diaphragm rather than at the distance of the cross hairs. Focusing of this image must be observed through the TV eyepiece either by using the TV camera itself or by visually observing the image through

this eyepiece. The TV eyepiece is permanently focused on the diaphragm itself, and the sample must be focused to bring the sample image into the plane of the diaphragm.

The focal length of the converging lens used to gather light into the monochromator must be selected to provide a divergence consistent with the $f/3.5$ monochromator. The optimal focal length for the converging lens depends on the magnification of the objective lens since this lens determines the diameter of the near parallel beam in the upper part of the microscope tube. Since we generally use a $20\times$ objective lens which yields approximately a 6 mm diam beam from our 0.3 mm diam sample, a 2 cm focal length converging lens was selected which provides a divergence near that which the monochromator can accommodate. If higher power objectives are used, only light from the portion of the image near the optical axis will strike the grating and be utilized in the monochromator.

The distance of the converging lens from the monochromator slit must be carefully and precisely adjusted for optimum operation. The function of this lens is to gather light to a minimum diameter and not to form an image. This is most efficiently accomplished by placing the image of the aperture defined by the objective lens itself at the slit of the monochromator. This location of the converging lens gives near uniform illumination across the slit, ensures that light from all portions of the sample passes through the slit, and gives the most narrow beam size at the slit consistent with the divergence. Furthermore, the amount of light passing into the monochromator does not depend on where the sample image is focused. The converging lens does form an image of the sample a few millimeters away from the slits when they are in their optimum position as just described. If the slit is erroneously placed at this image point, it acts in a way similar to the diaphragm, it restricts much of the available light, and the measured intensity becomes highly dependent on the focusing position. When using the 2 cm converging lens properly positioned, the beam converges to a diameter slightly less than 1.0 mm and over 60% of the available light passes through a 0.5 mm slit.

The monochromator is a $\frac{1}{4}$ m $f/3.5$ Ebert-mount commercially available unit supplied by the manufacturer with a standard grating of either 1180 grooves per mm or 2360 grooves per mm. The wavelength readout dial as supplied has a smallest scale division of 2 Å, specified resolution of 3 Å using 0.150 mm slits, and a reciprocal dispersion at 7000 Å of approximately 32 Å/mm. Pressure measurements of reduced precision (≈ 2 kilobars) can be readily made using this monochromator as supplied. The use of the echelle grating in the eighth order improves the precision (≈ 0.5 kilobar) and allows for more efficient light gathering due to larger slits.

The use of an echelle grating in such a small instrument is rather uncommon. To be of significant advantage, the

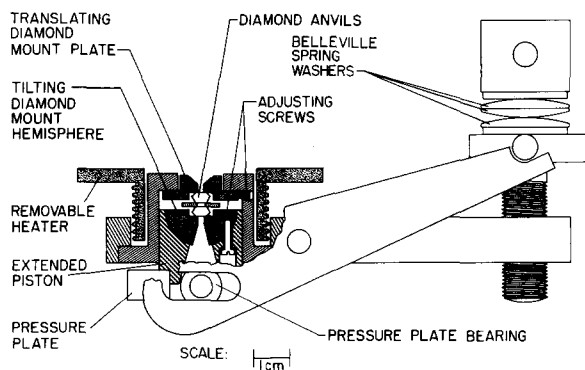

FIG. 3. Cut-away cross section drawing of the Waspaloy pressure cell showing improved alignment design, heater assembly, and spring washer configuration.

echelle must be used in higher order. This means that the light must strike the grating at an incident angle α (see Fig. 2) near its blaze angle (59° for the grating used). Such large angles are not allowed for in the normal grating mount of the monochromator and require an initial displacement of an angle ϕ , shown in Fig. 2, from the normal orientation of the mount. The ϕ of 37° used in our instrument was dictated by convenience in mounting. Adjustment of the existing wavelength drive makes possible incident angles from $\alpha = 37^\circ$ up to $\alpha = 75^\circ$.

The different grating constant (300 lines/mm) of the echelle and its initial angular displacement, ϕ , change the scale factor, and the zero of the wavelength drive scale. Because this change makes the scale nonlinear, an independent wavelength calibration of the scale using known spectral lines is required. The 6th, 7th, and 8th orders of the ruby *R*-lines at 6942 \AA are observable over the adjustable range of the monochromator with the mounted echelle. The eighth order provides the greatest dispersion, but the sixth order provides the greatest intensity. While making comparisons between fluorescent materials, we have observed overlapping between orders, but this is not serious provided unknown materials are not studied. Careful selection of filter B will eliminate overlapping in any routine use. It should also be noted that care must be taken that there is no significant slope in the transmission curve of this filter in the region examined or a variable error in peak position could occur.

Commonly used photomultipliers are relatively insensitive in the red portion of the spectrum where ruby and many other materials fluoresce. Specialized red-sensitive photomultipliers developed in recent years dramatically improve the sensitivity of the system. The highest quality tubes use a relatively small photocathode and require the use of a small lens to converge the light onto the photocathode as shown in Fig. 2. Lower noise levels can be obtained by cooling the photomultiplier, but this cooling has not been necessary. When using ruby as a pressure sensor at room temperature, signals of approximately 100

times the phototube dark current are common. The photomultiplier utilizes a conventional high voltage power supply operating between 1000 and 1400 V. The photocurrent is measured by a picoammeter with maximum sensitivity of 10^{-10} A (full scale) and with zero offset for suppressing the dark current of the photomultiplier. The photomultiplier tube overload protection is a built-in feature of the power supply.

IV. IMPROVEMENTS IN PRESSURE CELL DESIGN AND TECHNIQUE

Detailed descriptions of the diamond cell have been published previously.^{12,13} A few modifications relating to the extended use of the gasketed diamond cell to temperatures of 700°C at moderate pressures and to pressures near 200 kilobars at room temperature are given here. The high-temperature diamond cell is constructed with metal parts fabricated from a high-temperature super-alloy, designated by the trade name Waspaloy, which has a yield strength of 7000 kg cm^{-2} at 650°C , and 2800 kg cm^{-2} at 800°C . To produce the highest pressures at room temperature, heat treated high strength steels were used to support the diamonds. The essential parts of the new design are shown in Fig. 3. Only one movable piston is used in this design, and the piston and cylinder are increased in length compared to previous models in order to maintain the diamond alignment during operation. An improved diamond alignment technique has also been developed. One diamond is mounted in a hemisphere rather than the flat plate previously used. This hemisphere can be tilted in an arbitrary manner by three symmetrically placed adjusting screws to obtain parallel anvil faces. The other diamond is mounted in a plate which is translationally positioned for axial alignment by similar screw adjustments. The hemispherical design provides a large bearing surface for the applied load. In the previous design tilting screws were used to support this load and these screws failed when excessive load was applied. This new design allows one to align the diamonds by providing independent tilt and translational motions—a feature not characteristic of the former technique. Using these new diamond mounts, alignment is accomplished with greater precision, more stability under higher loads, and with more ease than in the previous design. An additional improvement consists of a sliding bearing which has been placed in the lever arm to accept the ends of the pressure plate as indicated in Fig. 3 to prevent binding of the piston in the cylinder. Working drawings of the improved cell are available on request.

A loose fitting removable heating coil, shown in cross section in Fig. 3, heats the anvil region of the cell. In effect, the sample is at the center of an externally heated furnace. The diamonds are cemented into the holding plates with a high temperature cement such as Fiberfrax. The coil spring

previously used has been replaced with Belleville spring washers which allow one to execute much more rapid changes in pressure. Spring washers with 136 kg capacity can be used in either series or parallel to alter sensitivity and load characteristics as desired.

The maintenance of hydrostatic conditions is the prime justification for the use of the metal gasket in the diamond cell. Use of the cell to contain liquid samples has not been extended previously to pressures above 40 kilobars, because most liquids solidify below this pressure. The development of the fluorescence pressure-measurement technique described herein allows a quantitative measurement of pressure gradients within the pressure chamber. This allows one to establish the limits of the hydrostatic range and to intercompare quasihydrostatic environments. It has been shown and will be reported in detail elsewhere¹⁴ that strictly hydrostatic conditions are possible to 100 kilobars at room temperature using a 4-1 mixture by volume of methanol and ethanol. Intercomparison of the pressure gradients using the gasketed and ungasketed techniques has also been made in quasihydrostatic environments. This work demonstrates the advantage of extending the use of the gasketed technique to higher pressures on a routine basis.

Higher pressures can be obtained using relatively small diamond-anvil faces (≈ 0.5 mm diam) in the former cell design, but with a relatively high incidence of failure. With the new hemispherical design larger loads, and thus larger diamond-anvil faces can be used. When higher loads are applied to Inconel gasketed liquid samples, the common occurrence is to burst the gasket if the gasket is too thick, and this bursting develops at lower pressures when operating at higher temperatures. The use of thinner gaskets (≈ 0.13 mm in contrast to 0.25 mm) extends the pressure range. The use of stronger gasket materials such as high strength Inconels, Waspaloy, and hardened tool steels extends the range even further, while still maintaining a usable thickness. We have used high strength Inconel alloys (750X) to ≈ 80 kilobars and have used the Waspaloy alloy to 200 kilobars. Measurements above 100 kilobars have become rather routine using Waspaloy gaskets. As might be expected, the sample chamber must be smaller in diameter relative to the diamond-anvil dimension when higher pressures are to be reached. The limiting factor in obtaining high loads, excluding the diamonds themselves, is the strength of the metal surface on which the table of the diamond rests. Thus, the hemispherical diamond mount and the translational diamond mount are fabricated from hardened steel consistent with the temperature range desired.

V. DISCUSSION

We have attempted to optimize the pressure-measuring system as described in Secs. I and III in an economical and

reasonable way, while maintaining a small versatile instrument. Our purpose was to obtain maximum signal intensity consistent with required resolution and desired measuring sensitivity. This optimization is necessary when one desires to make measurements at higher temperatures where the relative intensity of the fluorescent light is low. The system, as now operating, is so sensitive that when one uses red ruby (0.5% Cr) at room temperature and moderate pressure, a particle 10^{-6} mm³ in volume will yield a spectrum with peak intensity as large as the phototube dark current and thus readily measurable. Such a particle represents less than 0.1% of the cell volume. Individual particles this small cannot be purposely placed within the chamber, but measurements have been made of ruby fragments this small which have been left accidentally in the chamber or from optically isolated particles from a powder.

At temperatures above 200°C the situation is not so favorable, and meaningful spectra are obtained only with effort even when using ruby particles filling 10%-20% of the cell volume. Ruby spectra of marginal quality have been measured on samples at 400°C, but a more favorable fluorescing material will be required to extend the temperature capabilities.

The precision of measurements at high temperature is also seriously reduced by the increase in line width and the associated overlap of the R_1 , R_2 doublet. The two lines broaden and become unresolved above 200°C, and only the shift of the unresolved lines can be measured. The accuracy is also decreased since both temperature shifts and pressure shifts are experienced. Calibration measurements have been made using the water melting curve¹⁵ as a pressure reference at high temperatures to determine the pressure shift for the ruby fluorescence at elevated temperature. The measurements, to be reported in detail elsewhere,¹⁶ indicate that the pressure shift and the temperature shift are both approximately linear, in the same direction, and additive to 300°C and 30 kilobars.

Owing to the large temperature coefficient of ruby ($0.068 \text{ \AA}/^\circ\text{C}$), the sample temperature must be well known, and care must be exercised at low temperature to reduce the exciting light level to prevent undesired heating of the ruby.¹⁷ The effect is not so serious at high temperatures, since large amounts of external energy are already being put into the system.

The existence of the two R lines in the spectrum permits two somewhat independent measurements of the pressure. A comparison of the shifts of these two lines in several experiments to above 100 kilobars demonstrates that in hydrostatic experiments, the shifts of the two lines do not differ by more than 0.2 \AA at 100 kilobars. Thus, to within approximately $\frac{1}{2}$ kilobar either line or both can be used with the same calibration. This relative shift is slightly sensitive to uniaxial stress, and unrepeatable differences of

2 to 3 kilobars are observed under nonhydrostatic conditions. These results suggest that measurements of either line are only valid to within 2 or 3 kilobars in a nonhydrostatic environment at any pressure.

The fact that measurements can be made on such small particles of ruby makes possible the practical use of the diaphragm described in Section III to isolate particular localized regions of the sample. The iris diaphragm, which is an original feature of the microscope, will reduce to approximately 1.0 mm in diameter. When using a 20 \times objective lens an area approximately 0.04 mm in diameter can be isolated. Correspondingly smaller areas can be isolated when higher magnification is used. We have used the diaphragm extensively to study pressure variations over the sample region in non-hydrostatic environments. We have also used it to isolate particular particles of different fluorescent materials when making comparison measurements.

A knowledge of the reproducibility and accuracy, as well as the factors which limit them, is of fundamental importance in any measurement technique. We will discuss here only those factors which involve the reproducibility. Inaccuracies associated with the pressure calibration will be discussed elsewhere.¹⁶ Since only relative changes in wavelength are involved in the pressure measurement, the reproducibility is related directly to the repeated readability of the dial if proper care is taken not to disturb the apparatus in any way between the zero pressure and high pressure readings. Often, however, significant time elapses between these two measurements during which changes may occur. For example, the room temperature may change, or minor adjustments may be made on the microscope. The scanning motor and the recorder are manually synchronized in our system giving rise to a synchronization error which can be reduced by using slower scanning speeds. In ten repeated measurements of the ruby spectrum at high pressure during which typical motions of the objective lens and movable mirrors were made, a standard deviation of 0.05 Å was obtained which corresponds to 0.15 kilobar. A similar set of measurements taken at 1 bar had a similar deviation. This result suggests an ultimate reproducibility of ≈ 0.3 kilobar in a pressure measurement using this equipment.

The aberrations in the optical features of the monochromator are very significant if one desires precision of the order of 0.1 Å. The effective shift due to aberrations was determined for the instrument by measuring the fluorescence from a single small ruby crystal ($\approx 20 \mu$) positioned at different locations within the field of view seen by the grating of the monochromator. A variation of approximately 1 Å between the center and the edges of the grating field was observed. With proper positioning of the monochromator relative to the microscope the variation was made symmetrical about the center of the grating.

The measured reproducibility noted above of 0.05 Å was obtained using the diaphragm to reproducibly select a constant area near the center of the grating field, and care was taken not to move the sample during the measurements. This procedure effectively eliminates the aberration errors.

Maximum precision can be attained only if the 1 atm pressure spectrum and the high pressure spectrum are recorded on crystals of comparable size and located in a repeatable position. This is true because fluorescent light from a large crystal utilizes the total area of the grating and produces an average value of the 1 Å variation across the grating associated with aberrations. This average line position shows an apparent shift of approximately 0.4 Å compared to a small crystal which utilizes the center of the grating area only. To minimize aberration errors a very small crystal should be used and the movable objective lens should be rigidly on the optical axis of the system. If one used a fixed position objective lens, proper optical alignment could be permanently maintained, but this would require precision translational motions of the pressure cell, which are not built into our system.

Zero shifts which will generate errors in pressure measurement can also be produced by mechanical movement of any element of the optical system such as changing or even moving the slits of the monochromator, slight straining of the monochromator housing caused by thermal effects, or even movement. A more serious and less easily avoided effect is the temperature shift of the ruby lines.¹⁷ This shift is caused by temperature changes between the time of pressure reading and zero reading caused by either changes in ambient room temperature or by a high exciting light level.

If one is mindful of these aberration, mechanical, and temperature effects, it appears possible to make reproducible measurements of pressure to 0.5 kilobar, which, except for the lower pressure region, is much better than our calibration of the ruby line shift, and above 40 kilobar is better than the pressure scale is known. The facts that the reproducibility is relatively independent of pressure, and that this pressure calibration of the ruby shift as now known is effectively linear, suggest the use of the technique in basic pressure calibration as a secondary standard in the pressure range above 40 kilobar.

The development of this rapid pressure-measuring technique for the diamond cell has added to our understanding of the operation of the cell itself. For example, (1) pressure drifts for periods of several hours have been observed following sudden large changes (primarily decreases) in load; (2) at constant spring load, pressure changes caused by changes in temperature have been measured, but are not reproducible in either magnitude or direction; (3) very poor correspondence exists between pressure and spring load, depending upon cycling and temperature history.

After describing this microscopic fluorescence analysis

system with its specific application to high pressure measurement, we note that the apparatus itself might well be of significance to workers in other fields which involve the study of microscopic fluorescing samples. The wavelength resolution, light gathering ability, and light detection sensitivity are much superior to currently available units. This system can be used either with or without the echelle grating depending upon desirability. When using the echelle grating with narrow slits (0.05 mm), resolution as high as 0.8 Å, depending on the order used and the wavelength being studied, is possible.

ACKNOWLEDGMENTS

Partial financial support for the development of this apparatus was provided by Picatinny Arsenal, Dover, N. J. We wish to acknowledge R. A. Forman of NBS for helpful discussions and suggestions, and W. S. Brower and H. S. Parker both also of NBS for supplying various fluorescent materials for our evaluation. Also we wish to thank M. J. Weber of Raytheon for suggesting and providing the YAlO_3 samples, and G. A. Kieg of Union Carbide for supplying the YAG sample.

*On sabbatical leave (1971-1972) from Brigham Young University, Provo, Utah 84601.

- ¹C. E. Weir, E. R. Lippincott, A. Van Valkenburg, and E. N. Bunting, *J. Res. Natl. Bur. Stand. (U.S.) A* **63**, 55 (1959).
- ²S. Block, C. E. Weir, and G. J. Piermarini, *Science* **169**, 586 (1970).
- ³H. W. Davies, *J. Res. Natl. Bur. Stand. (U.S.) A* **72**, 149 (1968).
- ⁴G. J. Piermarini and C. E. Weir, *J. Res. Natl. Bur. Stand. (U.S.) A* **66**, 325 (1962).
- ⁵G. J. Piermarini, A. D. Mighell, C. E. Weir, and S. Block, *Science* **165**, 1250 (1969).
- ⁶C. E. Weir, S. Block, and G. J. Piermarini, *J. Chem. Phys.* **53**, 4265 (1970).
- ⁷H. A. Bassett, T. Takahashi, and P. W. Stook, *Rev. Sci. Instrum.* **38**, 37 (1967).
- ⁸W. A. Bassett, T. Takahashi, and M. K. Mao, *J. Appl. Phys.* **39**, 319 (1968).
- ⁹R. A. Forman, G. J. Piermarini, J. D. Barnett, and S. Block, *Science* **176**, 284 (1972).
- ¹⁰A. L. Schawlow, in *Advances in Quantum Electronics*, edited by J. R. Singer (Columbia U. P., New York, 1961).
- ¹¹D. E. McCumber and M. D. Sturge, *J. Appl. Phys.* **34**, 1682 (1963).
- ¹²C. E. Weir, S. Block, and G. J. Piermarini, *J. Res. Natl. Bur. Stand. (U.S.) C* **69**, 275 (1965).
- ¹³C. E. Weir, A. Van Valkenburg, and E. R. Lippincott, *Modern Very High Pressure Techniques*, edited by R. H. Wentorf (Butterworths, Washington, D.C., 1962).
- ¹⁴In preparation.
- ¹⁵C. W. F. T. Pistorius, E. Rapoport, and J. B. Clark, *J. Chem. Phys.* **48**, 5509 (1968).
- ¹⁶In preparation.
- ¹⁷H. K. Paetzold, *Z. Phys.* **129**, 123 (1951).
- ¹⁸M. J. Weber and T. E. Varitimos, *J. Appl. Phys.* **42**, 4996 (1971).