

Null Method of Measuring Microwave Phase Shifts

Andrew L. Gardner

Citation: *Review of Scientific Instruments* **37**, 23 (1966); doi: 10.1063/1.1719945

View online: <http://dx.doi.org/10.1063/1.1719945>

View Table of Contents: <http://scitation.aip.org/content/aip/journal/rsi/37/1?ver=pdfcov>

Published by the **AIP Publishing**

Articles you may be interested in

[A new method for measuring phase shift in heterodyne interferometric measurement](#)

Rev. Sci. Instrum. **61**, 1442 (1990); 10.1063/1.1141149

[Simple microwave interferometer for measuring small phase shifts with high spatial resolution](#)

Rev. Sci. Instrum. **47**, 1201 (1976); 10.1063/1.1134801

[Method for Measuring Phase Shifts at Ultrasonic Frequencies](#)

J. Acoust. Soc. Am. **46**, 79 (1969); 10.1121/1.1973479

[Microphone Diaphragm Null Method for Sound Pressure Measurement](#)

J. Acoust. Soc. Am. **32**, 505 (1960); 10.1121/1.1908115

[Phase Shift Method of Carrier Lifetime Measurements in Semiconductors](#)

Rev. Sci. Instrum. **29**, 889 (1958); 10.1063/1.1716029

Nor-Cal Products



Manufacturers of High Vacuum
Components Since 1962

- Chambers
- Motion Transfer
- Flanges & Fittings
- Viewports
- Foreline Traps
- Feedthroughs
- Valves



www.n-c.com
800-824-4166

Null Method of Measuring Microwave Phase Shifts*

ANDREW L. GARDNER†

Lawrence Radiation Laboratory, University of California, Livermore, California 94550

(Received 2 October 1964; and in final form, 19 July 1965)

A companion paper by Gardner and Hawke described a microwave phase shifter, with constant output, capable of rapid phase control by the bias voltage applied to varactor diodes. This paper describes the application of this device to measure phase shifts in a cw microwave system by a null method. If phase and amplitude variations are not too fast, standard oscilloscope components can provide most of the required circuitry. Examples are given, including the measurement of 0.003° phase shift at 9 Gc in a plasma experiment.

INTRODUCTION

THE method described here was used to measure 0.003° phase shifts in the plasma of the Alice experiment¹ at this Laboratory. (A description of the experimental conditions, including an interpretation of the phase shift measurement, is given by Damm *et al.*²) In this experiment, which at the time employed a simple magnetic mirror geometry, the plasma of about 24 cm diameter is built up by Lorentz force ionization of a small fraction of a beam of 20 keV neutral hydrogen atoms as it passes diametrically through the trapping region. The plasma is maintained for a few seconds during each test run.

A preliminary survey of the possibility of using resonant cavity techniques to measure the electron density of the plasma indicated that no suitable resonance modes could be established without modifying the internal structure of the chamber. It was then decided to try measuring the phase shift of a 9 Gc microwave beam transmitted twice through the plasma. Access to the plasma was made via existing 12.7 cm i.d. pipes that extended radially from the central chamber.

Various factors were considered in deciding to use a reflector and two "passes" through the plasma: (1) the second traversal doubles the observed phase shift; (2) a focusing reflector can tolerate metallic coatings deposited by the gettering vacuum pump (which a dielectric lens cannot); (3) only one microwave vacuum window is required; (4) the microwave plumbing is simplified; and most important, (5) by imparting a measured small radial movement to the reflector, the over-all phase measuring system may be directly calibrated (for the accuracy required we here neglect the divergence of the microwave beam).

The possibility of launching a beam that would converge to a focus on the axis was considered but abandoned because of the design work required and because the small size of the entrance port imposed severe limitations.

* Work performed under the auspices of the U. S. Atomic Energy Commission.

† Present address: Department of Physics, Brigham Young University, Provo, Utah 84601.

¹ C. C. Damm, A. H. Futch, F. Gordon, A. L. Hunt, E. C. Popp, R. F. Post, and J. F. Steinhaus, *Nucl. Fusion* **1**, 280 (1961).

² C. C. Damm *et al.*, *Phys. Fluids* **8**, 1472 (1965).

The "heart" of the measuring system consists of a phase shifter³ which uses the voltage-variable capacitance of varactor diodes to provide a phase shift that may be varied rapidly while the output amplitude remains constant. This permits the use of an unmodulated cw microwave source and simple "oscilloscope circuitry" in a null type bridge for measuring phase shifts.

BASIC CIRCUITS

Figure 1 shows two basic microwave interferometer or bridge circuits useful for measuring phase shifts. In each case the microwave power is divided at the input tee and sent along different paths in the test arm and the reference arm. The two signals later recombine in a tee (the same tee in the reflection bridge) where half of each signal is sent to the detector. An adjustable phase shifter is incorporated in the reference arm of the bridge—in the present discussion the phase shift of this component is controlled by the bias voltage applied to its varactor diodes. The locations and the number of isolators required depends upon the quality of the matching (and isolation) of the other components. Since an unmodulated cw microwave source is used, the matching of all components to the line impedance may be optimized for a particular frequency. For greatest sensitivity in locating the reference phase that produces an output minimum (i.e., in balancing the phase bridge), the signals from the two paths should be comparable in magnitude; an attenuator may thus be desirable in the path that otherwise has least attenuation. A manually adjustable phase shifter may also be included in one arm to allow initial balancing of the bridge in the optimum range. However, reflections from an attenuator or auxiliary phase shifter may be serious, especially in the circuit shown in Fig. 1(a).

To measure the unknown phase shift $\Delta\phi_x$ one determines the change of the varactor bias voltage (calibrated vs reference phase shift $\Delta\phi_{ref}$) that is required to restore the bridge balance. The best way to do this depends upon the rate and amount of change of both phase and amplitude that the signal undergoes in the test path.

³ A. L. Gardner and R. S. Hawke, *Rev. Sci. Instr.* **37**, 19 (1966), (preceding paper).

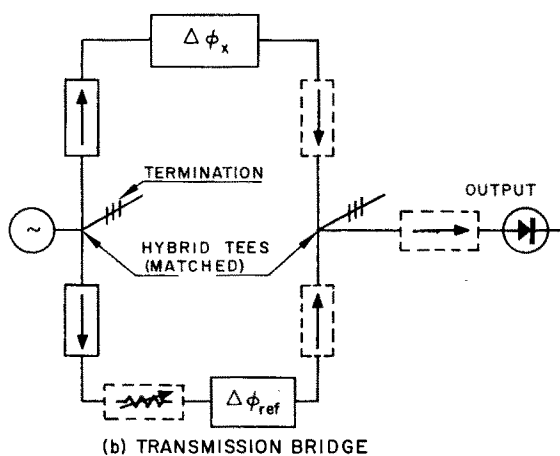
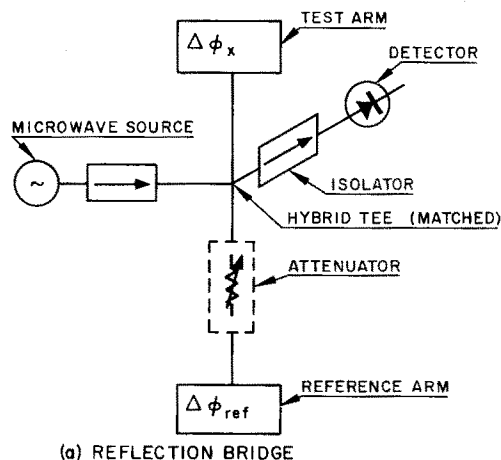

FIG. 1. Microwave interferometer or bridge circuits for measuring phase shifts.

The phase shifter employed is inherently a fast device that is adaptable to circuits by which a continuously varying phase shift may be tracked automatically over any amount of phase shift. However, this account deals with the cases in which phase variations are moderate (less than 360°) and in which the phase and amplitude do not change appreciably in a few microseconds; in such situations the oscilloscope circuitry presently available is adequate for continuous measurements of a changing phase shift.

In such cases a fraction of the sawtooth sweep voltage from an oscilloscope or a sweep generator may readily be used to sweep the $\Delta\phi_{ref}$ phase repeatedly over the required dynamic range.⁴ One minimum of the detector output thus occurs at phase null during each rise of the sawtooth, i.e., at that instant when the phase of the rf power from the reference arm of the bridge differs by 180° from the

⁴ To obtain $\Delta\phi_{ref}$ control up to 360° requires the added effect of three or more phase shifters of the type described by Gardner and Hawke (see Ref. 3) and results in correspondingly higher attenuation. A circulator is convenient for connecting additional units or for adapting a reflection type phase shifter for an application requiring a transmission type unit.

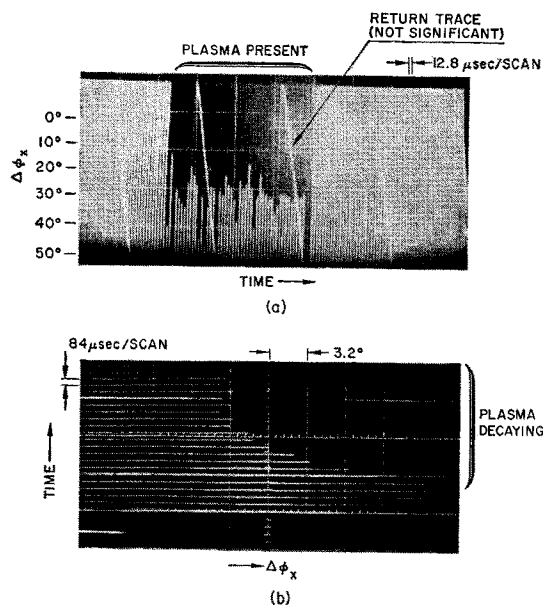

FIG. 2. Examples of raster display of phase shift. (a) Phase shift of a 24 Gc wave reflected from a dense turbulent plasma at a sharp boundary (compared to metallic reflection as 0°). (b) Phase shift of a 9 Gc wave transmitted through a plasma.

phase of the rf power from the test arm of the bridge. Differentiation of the output yields a signal that passes through zero (with a slope that is always positive or always negative) at the time of the minimum of the original signal from the detector. Such a differentiated signal is well suited to trigger a second oscilloscope sweep circuit at the time of the original phase null and a gate pulse from the second sweep circuit may be introduced into a simple circuit, together with the original sawtooth, to identify the time of the phase null and consequently the phase shift itself.

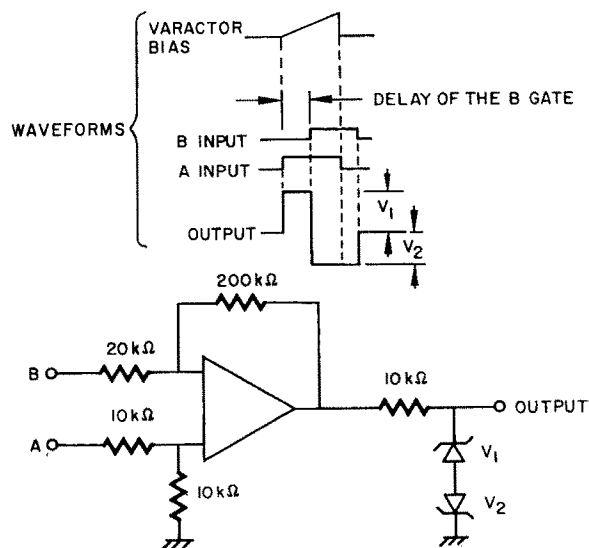

FIG. 3. A circuit with an average output voltage that changes linearly with the delay of the B gate.

APPLICATION OF THE TECHNIQUE

The desired phase information may be retrieved in various ways. Figure 2 shows two examples in which the repeating sawtooth sweep voltage is applied to the viewing 'scope to give a raster presentation. Blanking of a portion of each trace is started at the time of the phase null. Figure 2(a) gives some idea of the time resolution that is obtainable with this method using 'scope circuitry. In this case the phase shift was that of a 24 Gc wave reflected from a dense, turbulent plasma at a sharp boundary (normalized to 0° for a metallic boundary reflection). The erratic variations were attributed to the fluctuations in plasma density. Figure 2(b) shows the phase shift of a 9 Gc wave transmitted through a plasma.

If the variations in phase shift are very much slower than the period required to scan the reference phase, it is possible to scan frequently and to average the results of repeated sensing of the null phase. If, for each scan, one develops a waveform that has an average voltage proportional to the instantaneous voltage of the sawtooth at the null, then the phase information may be averaged over many scans with an integration circuit having appropriate time constants.

Such a waveform may be derived in various ways. One simple method, shown in Fig. 3, uses an operational amplifier (e.g., Tektronix type O plug-in unit) as a difference amplifier that is fed by two positive gate pulses A and B which are readily obtained from oscilloscope sweep cir-

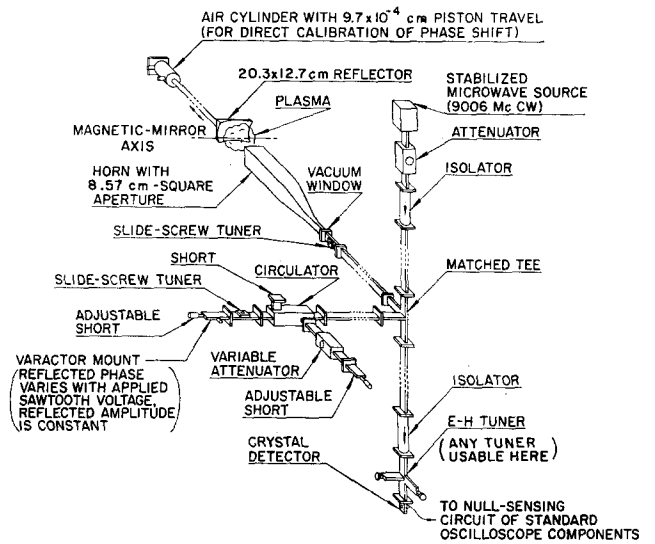

FIG. 4. Microwave circuit used in the Alice experiment.

cuits. Gate A is on for the duration of the sawtooth sweep which is applied to the phase shifter, and gate B is initiated at the time of the phase null. This circuit yields an output voltage of $+V_1$ when the A positive gate only is on and an output of $-V_2$ when the B gate only or both A and B gates are on. The Zener diodes and the dropping resistor clip the output at values of $+V_1$ and $-V_2$ volts. Even if the output clipping circuit is not used, the output voltages of the type O amplifier in effect are clipped because

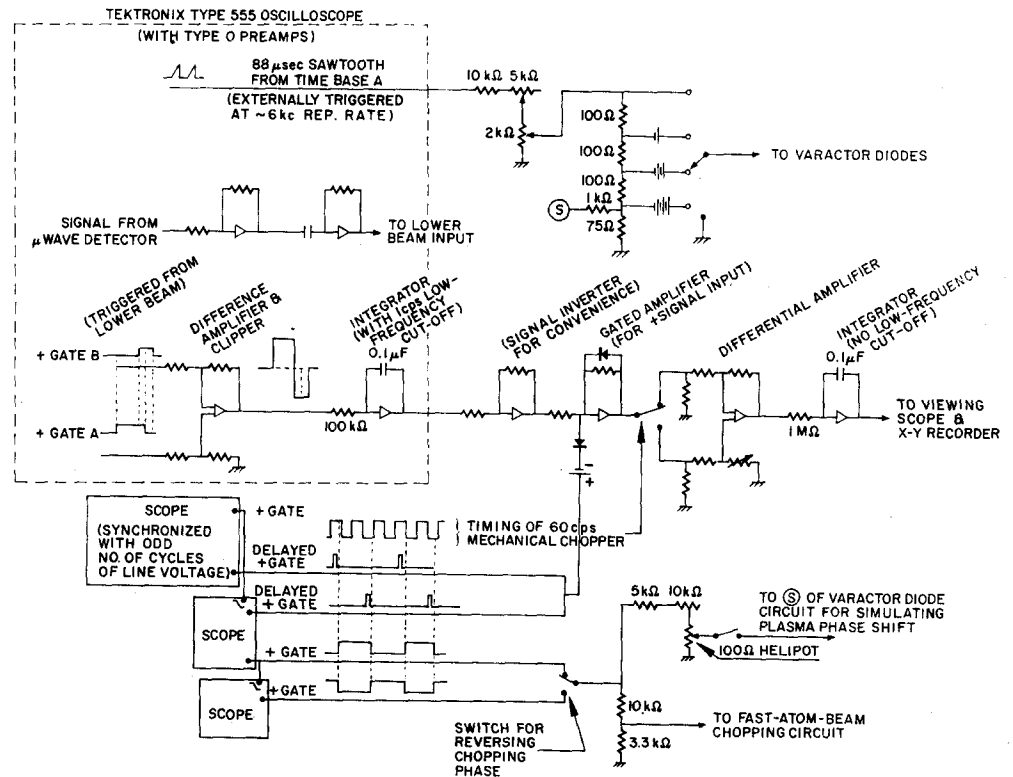

FIG. 5. A synchronous detection circuit used for measuring 0.003° phase shifts in the Alice system.

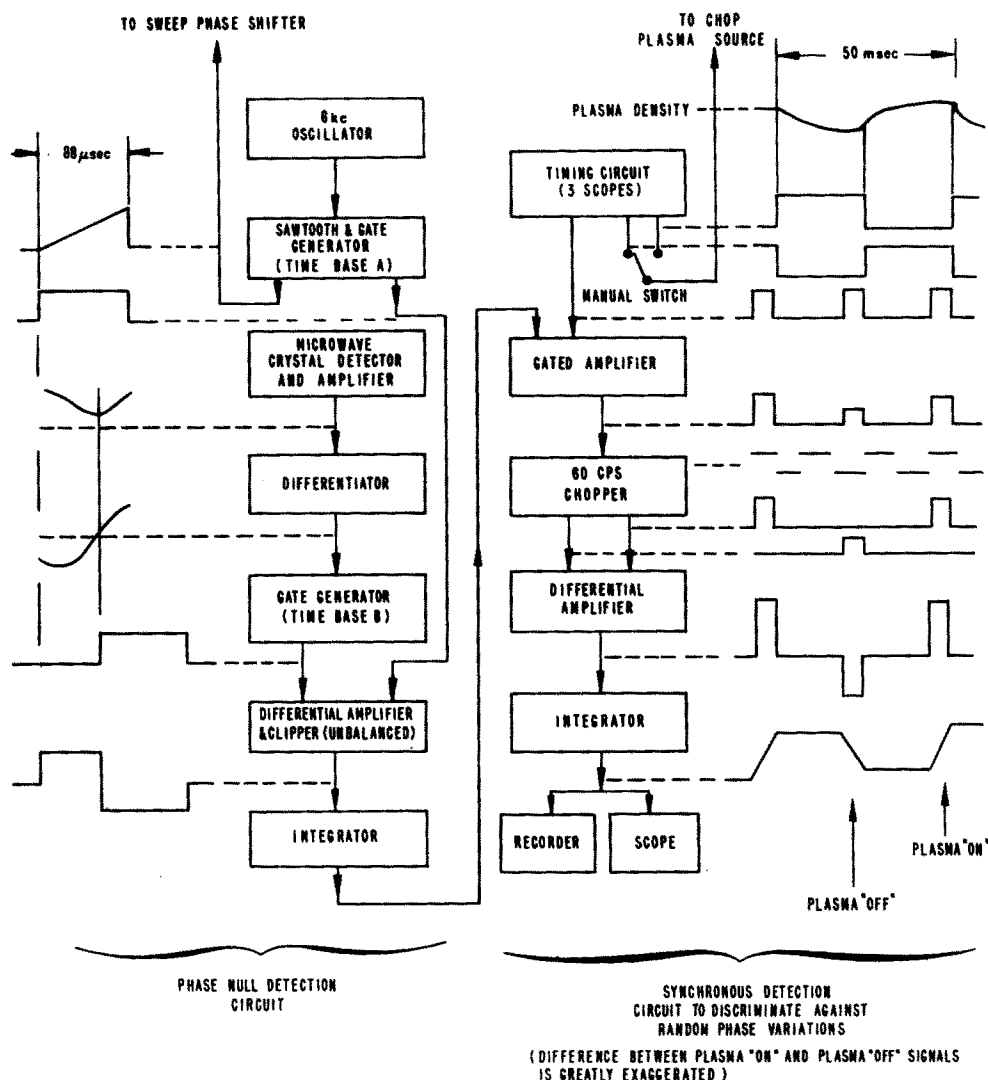

Fig. 6. Block diagram and waveforms of the detection circuit.

with 20 V gates the amplifier is driven to its limiting plus and minus values (over 50 V). Besides assuring a waveform with flat top and bottom, use of the reference diodes permits greater flexibility. For example, with A and B sweeps of equal length (desirable for greatest range of phase measurement with the circuit of Fig. 3), one obtains an average output voltage of one polarity (negative) by choosing $V_1 = V_2$, whereas if one selects diodes with $V_1 = 2V_2$, the average output voltage is offset to give opposite polarity but equal amplitudes at the extremes of the range.

EXAMPLE OF MEASUREMENT OF SMALL PHASE SHIFT

The microwave circuit used in the Alice measurements is shown in Fig. 4. The horn used had the largest square cross section the entrance port would accommodate, and its 25.4 cm section of full size was preceded by a 30.5 cm section with circular arc tapers from RG-52/u waveguide. At the aperture of the horn the vertical walls ended in concave arcs of 12.7 cm radius to permit a closer approach

to the plasma. The horn and window together produced a vswr of 1.04 (which was reduced to 1.01 with a slide-screw tuner).

The reflector, with a spherically concave surface of 27.94 cm radius, was positioned approximately 23 cm from the end of the horn. This geometry resulted in a return signal loss of 1.5 dB in bench tests without the vacuum chamber or other reflecting surfaces present. Further tests showed that the presence of an absorbing barrier with a 7.6 cm diam hole (or a horizontal slit 6 cm wide) interposed midway between horn and reflector resulted in a further signal reduction of 3 dB.

The plasma arm and the phase shifter arm of the microwave bridge differed by a length which rendered the overall system insensitive to small frequency changes of the microwave source in the initial installation.⁵ Subsequent use of a well-stabilized signal generator made this refinement unnecessary, but did not improve the performance.

⁵ The difference in length was adjusted until changes of frequency to either higher or lower values would cause the apparent phase shift to change in one direction only.

In the working system the principal "noise" of the measurement was attributed to positional changes of various surfaces inside the main chamber. These caused phase changes of the order of a few hundredths of a degree at frequencies up to a few cycles per second. Such variations are possible, even if the horn and reflector remain perfectly fixed, because 30% of the power is not returned directly via a single bounce from the reflector but undergoes multiple reflections from various surfaces within the chamber. Some of this power is ultimately radiated out of various ports of the chamber, but some returns to the horn. Substantial phase changes were thus seen when various electrodes or other diagnostic equipment were moved within the chamber or when liquid nitrogen was occasionally run through the cooling tubes of the chamber liner.

To discriminate against the random phase fluctuations, the plasma was modulated by chopping the fast atom beam input at rates of 20 or 60/7 cps with 50% duty ratio. This permitted a type of synchronous detection to be used in which the microwave phase was sampled during a 5 msec period just before the end of each half-cycle, and a gated integrating circuit alternately added and subtracted the resulting signals. It was necessary to introduce additional background gas to accelerate the decay of the plasma, but even so the observed phase shift was in the range of 10-80% of what it would have been if the plasma decay had been instantaneous.

The circuit which followed the microwave crystal detector is shown schematically in Fig. 5 and as a block diagram in Fig. 6. The entire lefthand portion of the Fig. 6 circuit, excluding the 6 kc oscillator and the crystal detector, were provided by use of a Tektronix 555 oscilloscope with type O plug-in amplifiers. (The oscillator requirement can be avoided by operating time base A in a free running condition.) Such a circuit, which does not have the synchronous detection feature, was shown to be capable of phase shift measurements of less than 0.1° with a response time of 0.01 sec.

TABLE I. Summary of phase shift measurements in Alice.

Test shot	Mean sampling time from "beam-off"	Measured phase shift (thousandths of one degree)			Weighting factor	Weighted mean phase shift
		'Scope	Re-corder	Mean value		
a	0.022 sec	3.97	2.73	3.35	1.0	0.0032° ± 0.0003°
b	0.022	...	3.04	3.04	0.7	
c	0.022	7.89	6.71	7.30	0.7	
d	0.022	3.53	3.22	3.38	1.4	
e	0.022	2.66	2.73	2.70	0.8	
f	0.022	...	2.42	2.42	0.7	
g	0.022	2.66	3.07	2.86	1.0	
h	0.022	1.03	1.50	1.26	0.5	
i	0.022	3.41	3.25	3.33	1.0	
j	0.022	2.01	2.71	2.36	0.9	
k	0.055	5.16	4.39	4.78	1.0	0.0070° ± 0.0008°
l	0.055	...	8.38	8.38	0.9	
m	0.055	7.74	8.38	8.06	1.0	

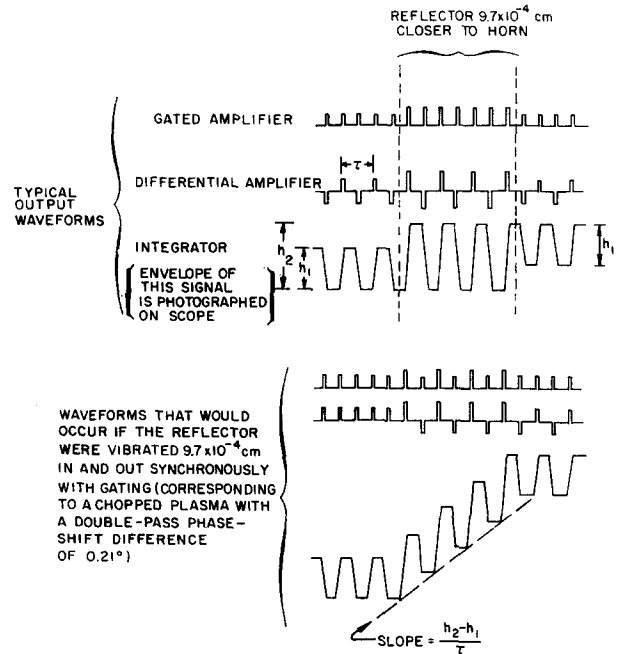

FIG. 7. Waveforms to illustrate the calibration technique.

The "clipping" of the waveform developed from the A and B gates was achieved by driving the amplifier to its saturation limits (without the use of the Zener diodes shown in Fig. 3). Since a wide range of phase shift was not involved, the B time base was used with a sweep time only about one-half that of the A time base, and adjustments were made so that only one polarity of output signal was obtained from the first integrator; thus simplifying the circuit of the gated amplifier which follows it.

The timing oscilloscopes provided positive gates which precisely controlled the fast atom beam chopping circuit and the gated amplifier. The 60 cps mechanical chopper served as a highly symmetrical switch and, because its "make" time overlapped each sampling time, it introduced no signal unbalance or "noise" due to its own jitter. To permit high sensitivity, the differential amplifier and the integrator following the mechanical chopper were carefully balanced.

With this method of detection the average rate of change of the output signal, from the final integrator with no instrumental drifts present, would thus be proportional to the difference in the amount of phase shift during the "plasma on" and "plasma off" samples. The instrumental drifts could have been ascertained by observing the slope of the recorded signal before and/or after the period during which the "chopped" plasma was present. This would have still left some question as to whether the presence of the chopped plasma itself might have indirectly affected the slope of the output during the test run. To circumvent both problems the fast atom beam chopping phase was changed by 180° a few times during each run, with nothing else altered (including the phase of the gated integrator). The

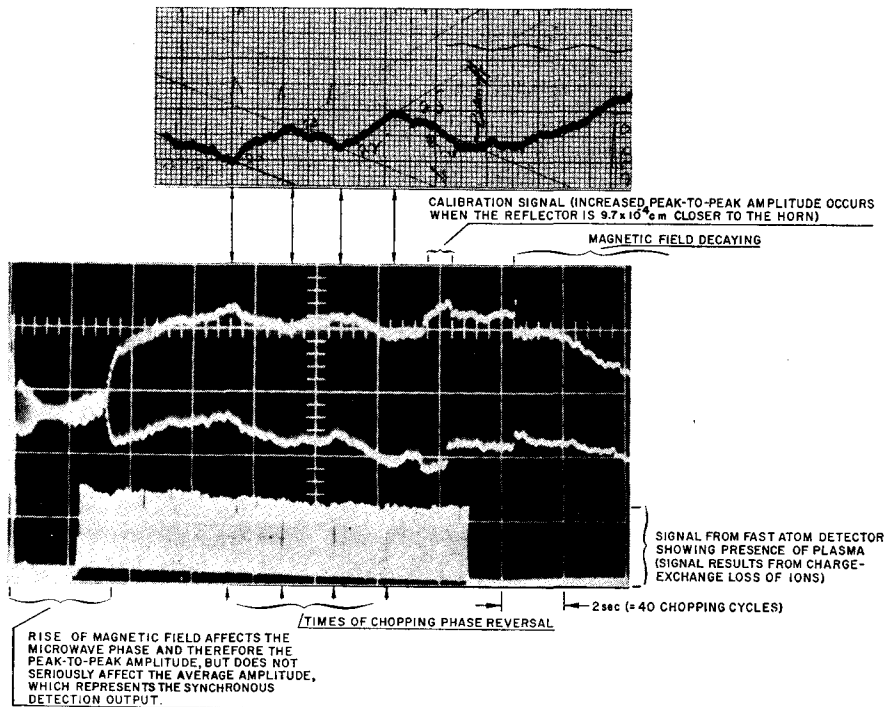

FIG. 8. Photographs of the recorded data for "shot d" of Table I.

quantity observed was the change in signal slope that occurred at the time of the reversal.

A pen recorder and an oscilloscope were both used to record the integrated output of the synchronous detector. The oscilloscope had a response fast enough to follow the rise and fall of the output during the sampling times of each chopping cycle, i.e., to follow the last waveform shown in Fig. 6. Absolute phase shift calibration was achieved by measuring the increase in amplitude of these fast excursions that resulted when the microwave reflector was moved radially inward 9.7×10^{-4} cm. This motion was imparted by an air operated piston that moved between fixed stops and was measured with a differential transformer.

The method of making the calibration is illustrated in Fig. 7 which shows how the slope of the recorded signal would change by $(h_2 - h_1)/\tau$ due to the presence of a completely chopped plasma with a total (double pass) phase shift of 0.21° (which corresponds to twice the free space difference over 9.7×10^{-4} cm). The envelope of the third waveform of Fig. 7 may be compared with the oscilloscope photo shown in Fig. 8. On the photograph the altered position of the reflector is seen to cause an increase in peak-to-peak amplitude $h_2 - h_1$ of about 0.5 division. Since the horizontal sweep rate is 2 sec (= 40 chopping cycles)/division and $\tau = 0.05$ sec (= 0.025 division), a synchronously chopped phase shift of 0.21° would produce an average slope of $(h_2 - h_1)/\tau = 20$, and upon reversal of its chopping phase a change of slope of ± 40 would result. The observed change of slope, about 2 orders of magnitude smaller, is proportional to the phase shift produced by the chopped plasma. The tacit assumption of linearity of the phase shifter is especially good at such small phase shifts.

A second method was also used to calibrate the phase shift corresponding to a given change of slope of the output signal. This consisted of superimposing a small square-wave voltage on the varactor sweep voltage in synchronization with the chopping. With the plasma off, but the chopping circuit operative to provide the synchronous detection, this artificial means could simulate the microwave phase shift of the plasma (including a phase reversal to cancel the effect of drifts). This simulated signal was also calibrated with the oscilloscope as described above.

Table I gives the results of measurements during the thirteen consecutive runs. The weighting factor assigned to each shot represents an attempt to reflect the various elements which affect the reliability of the measurement, e.g., the number of chopping phase reversals used and the apparent freedom from spurious effects. Although plasma operating conditions were similar, some of the shot-to-shot variations may be attributed to the plasma itself. In spite of this, the scatter in measured values indicates the weighted mean phase shift for the first ten shots has a probable error, as a result of random fluctuations in the measurement and the plasma, of only 3×10^{-40} .

ACKNOWLEDGMENTS

The author is indebted to Dr. C. C. Damm and the members of his research group for their cooperation during the measurements on the Alice system, and particularly to W. J. Stroh who assembled much of the apparatus and assisted in making these measurements. The encouragement given by Dr. C. M. Van Atta and Dr. R. F. Post is also appreciated.