

Announcements – 24 Sep 2013

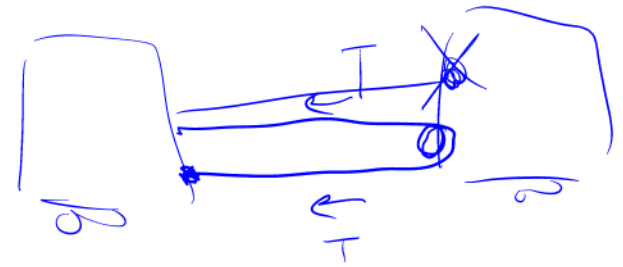

1. If you have **questions on exam 1...**

2. **Newton's 2nd Law Problems:** $\sum \vec{F} = m\vec{a}$

- a. Inclined planes
- b. Pulleys
- c. Ropes
- ✓ d. Friction
- e. Etc

→ Remember **N2 is a blueprint** for obtaining a useful equation; it's not the final equation itself.

The “ $\sum F$ ” on the left hand side means you have to consider all of the forces from your FBD and include them on the left hand side.

Do not put any forces on the right hand side!

Worked Problem from last time

You push with a force of 200 N on a 25 kg frictionless ice block which is on a hill sloping 30° above the horizontal. What is the acceleration of the block? Use $g = 10 \text{ m/s}^2$.

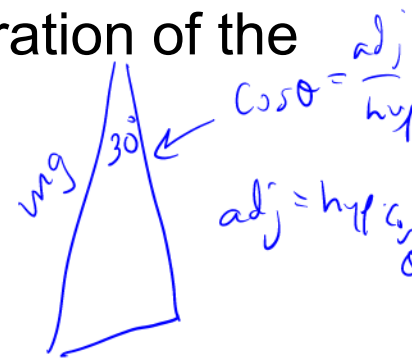
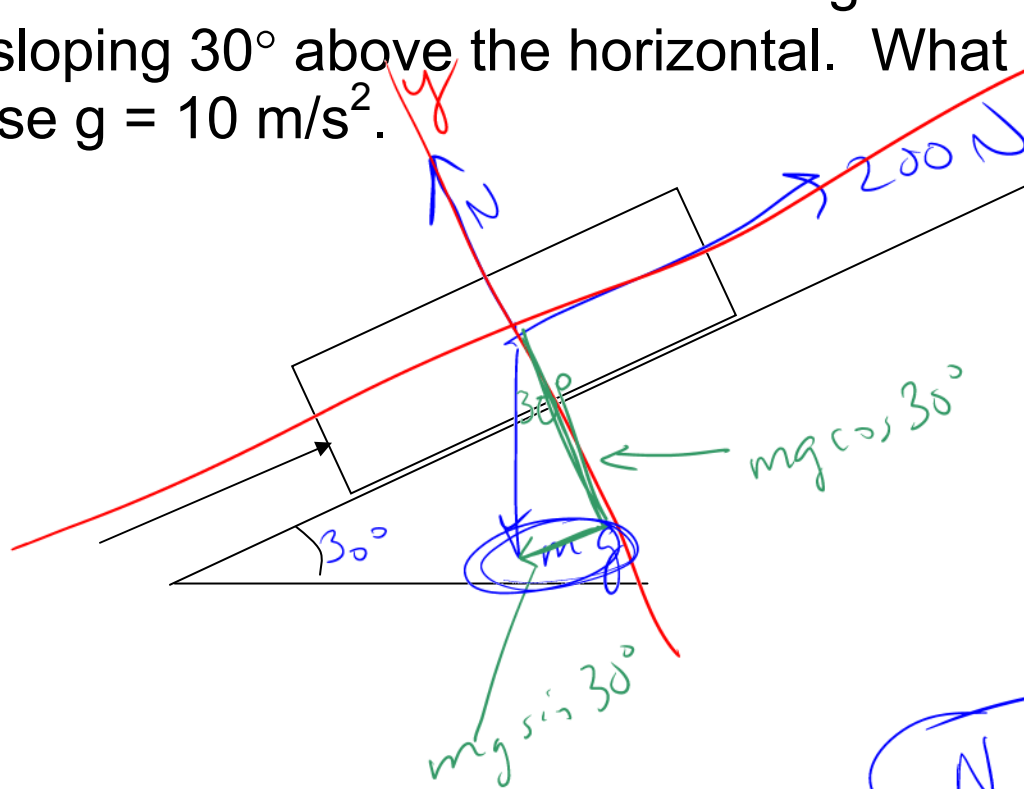
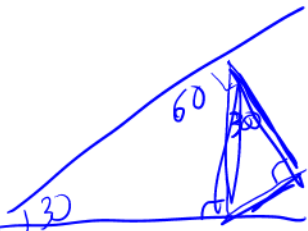

$$\sum F_y = ma_y = 0$$

$$N - mg \cos 30^\circ = 0$$

$$\sum F_x = ma_x$$

$$200 \text{ N} - mg \sin 30^\circ = ma_x$$

$$\rightarrow \frac{200 - (25)(10)\sin 30^\circ}{25} = a$$

$$a = 3.0 \text{ m/s}^2$$

$$N = mg \cos 30^\circ = (25)(10)(\cos 30^\circ)$$

Answer: 3.0 m/s^2

Accelerating Reference Frames

Demo: Rotating chair, Ball on string

To be able to ascribe accelerations to *real* forces, you must be observing the motion from a **non-accelerating (constant velocity) point of view**

Physics lingo: “point of view” = “reference frame”

Amusement Park Ride: Circular room spins, floor drops out. What are the forces on you?

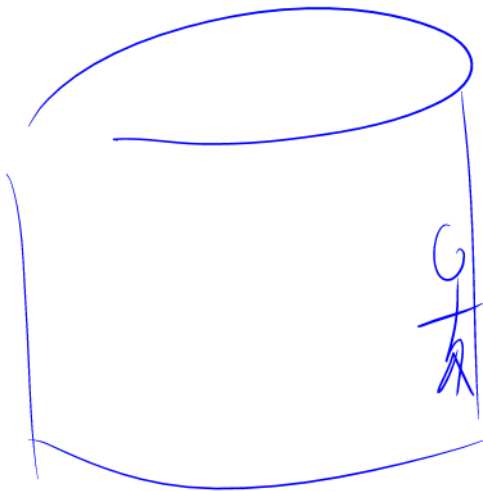

Fictitious Forces

In **accelerating** reference frames, we tend to invent **fictitious forces**.

Another example: Coriolis force



Clicker quiz

A car rounds a curve while maintaining a constant speed. Is there a net force on the car as it rounds the curve?

- a. No, because its speed is constant
- b. No, because it's in an accelerated reference frame
- c. Yes, because it's changing direction
- d. Yes, because it's slowing down

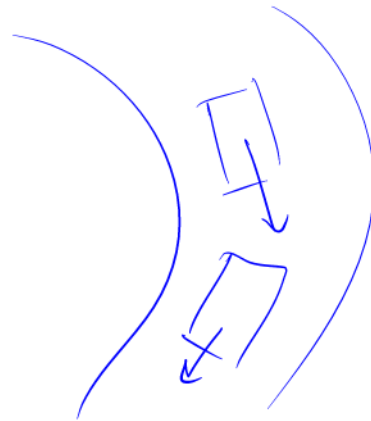

Clicker quiz

A car hits a large icy spot on the road at point P. What is the path of the car if there is no friction on the ice?

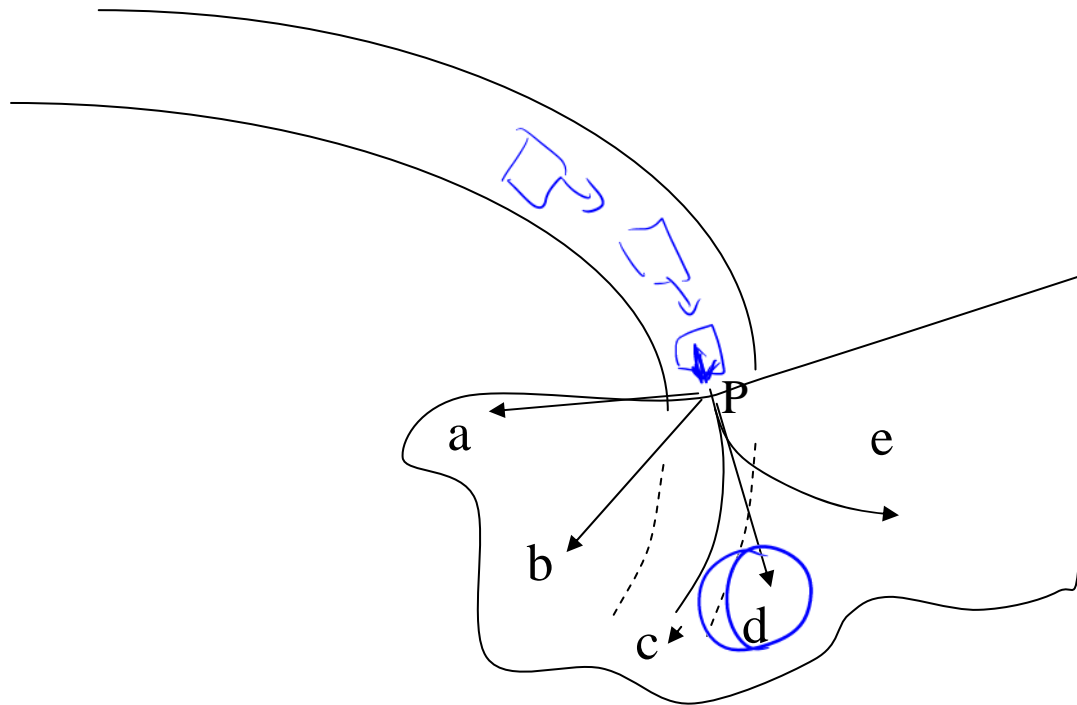

Clicker quiz

Which box is easier to get moving? (same box, same F)

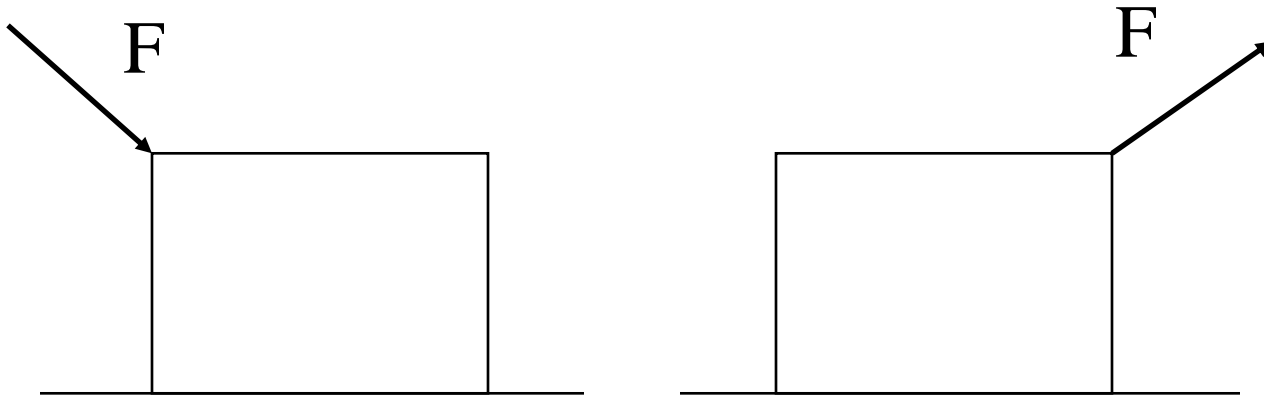

- a. left is easier
- b. right is easier
- c. same

Friction depends on N !

Why?

Friction depends on the Normal force

$$f \sim N$$

$$f = \mu N$$

"mu"

"coefficient of friction"

Friction depends on whether it's already "sliding"

Demo: static vs. kinetic friction

Book figure:

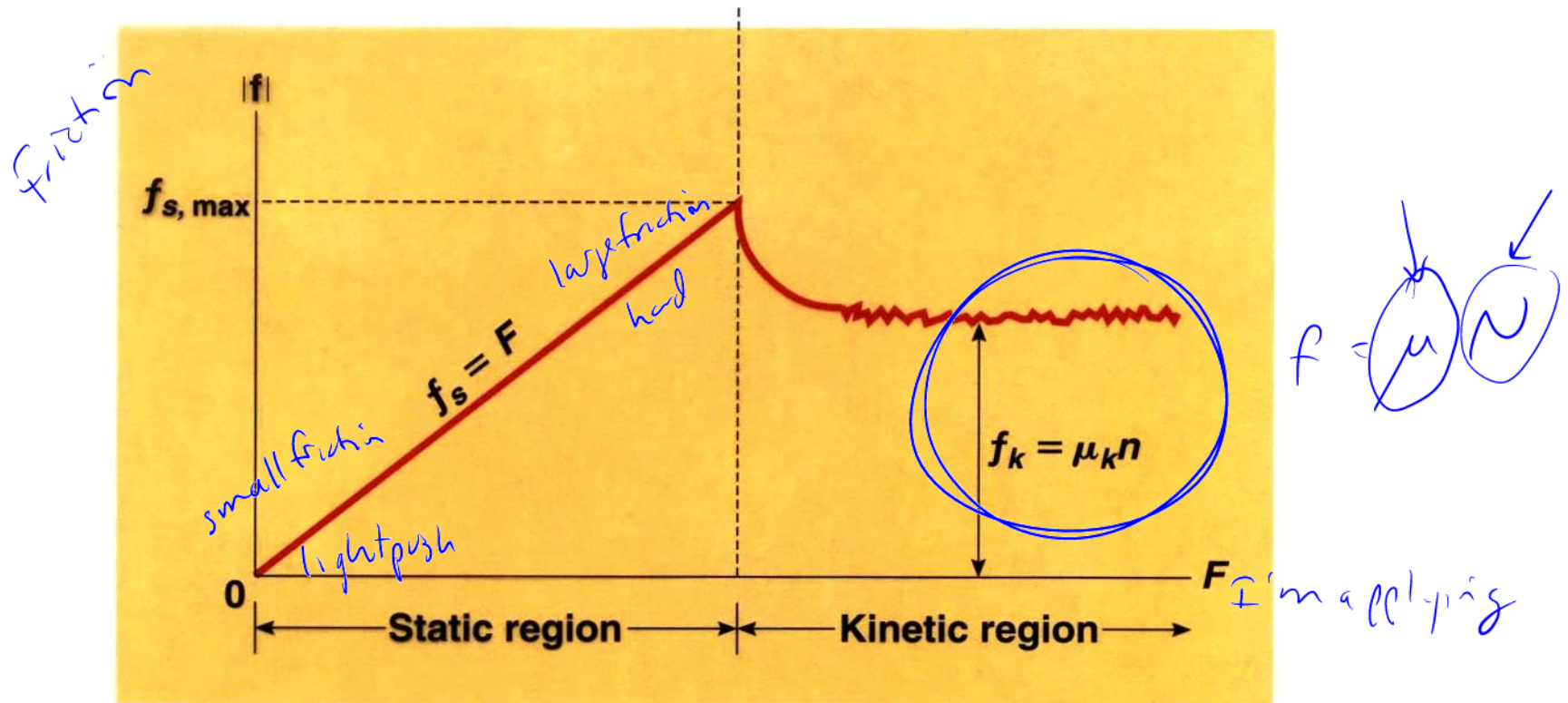

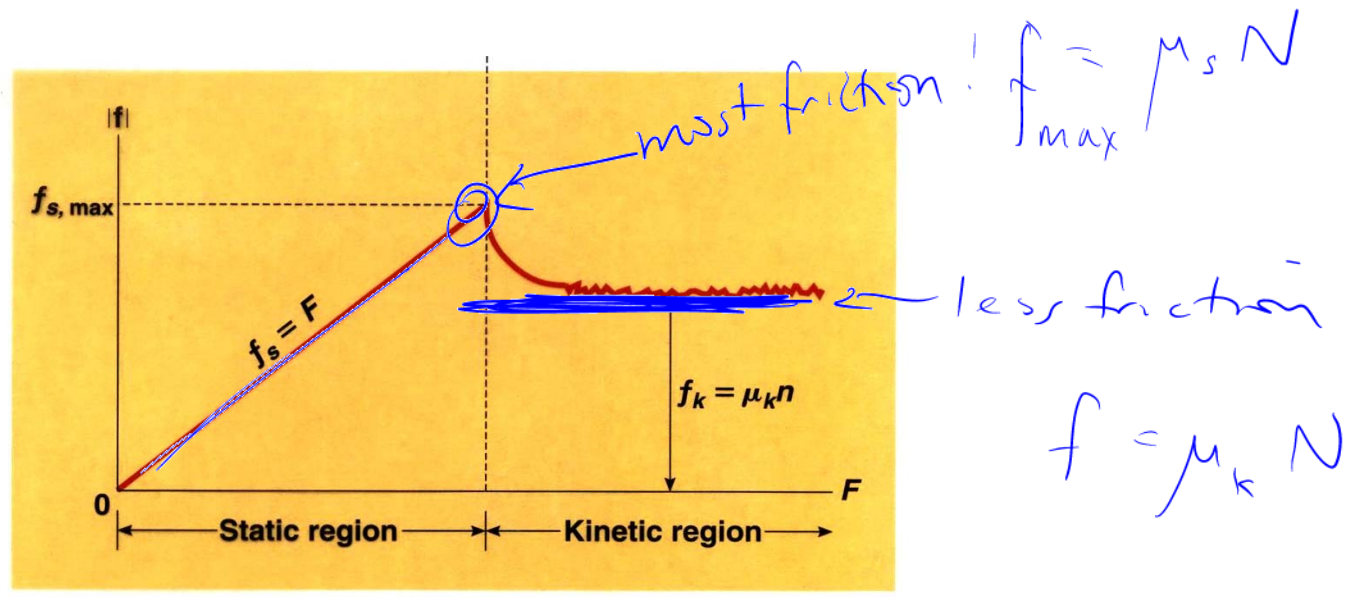

Compare with the forces when you break a rope tied to a wall. What is the tension in the rope?

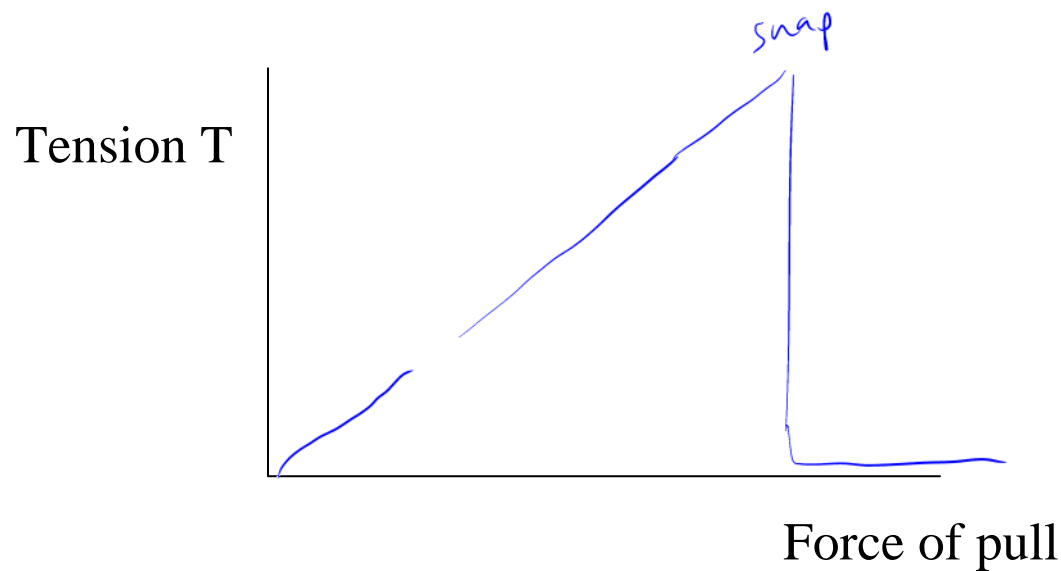

Kinetic Friction

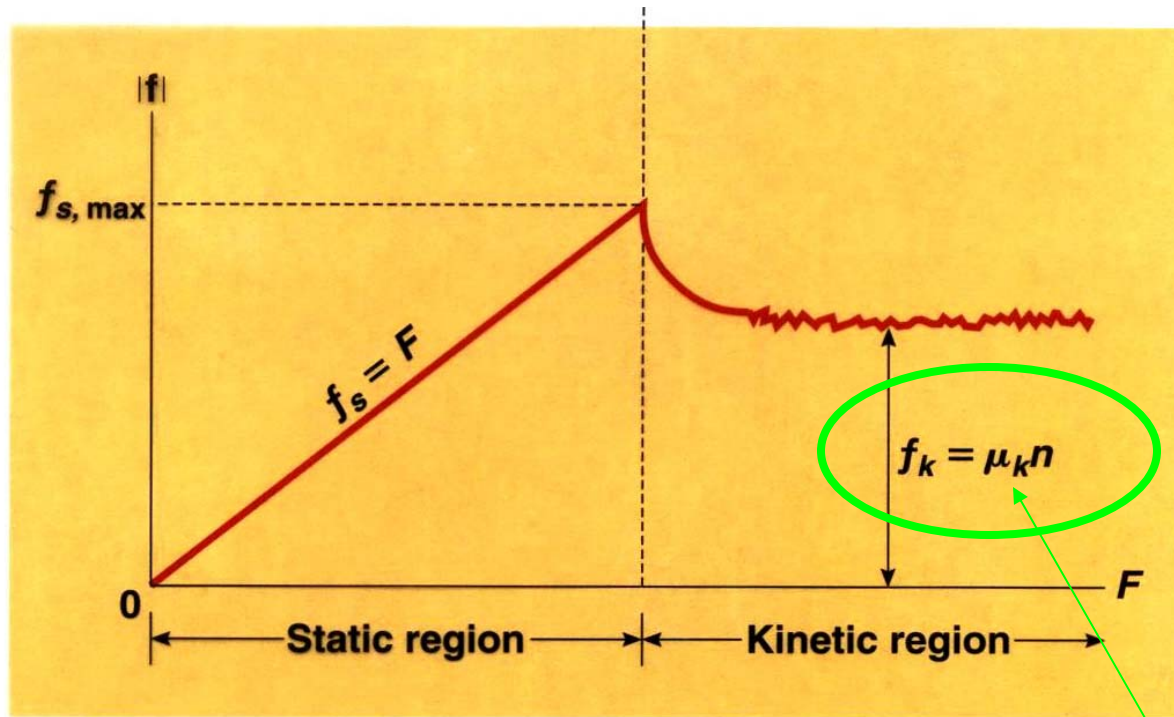

mu = "coefficient of friction"

From warmup

Ralph noticed that in the equation for the force of static friction, there's a "less than or equal to" sign, but in the equation for kinetic friction, there is a plain equals sign. He wants to know why they are different. What should I tell him?

“Pair share”—I am now ready to share my neighbor’s answer if called on.

a. Yes

$$f \leq \mu_s N$$

Static Friction

Grows with sideways force, to a point....

Before slipping pt:

Friction force is increasing

At slipping pt:

Friction force is maximal

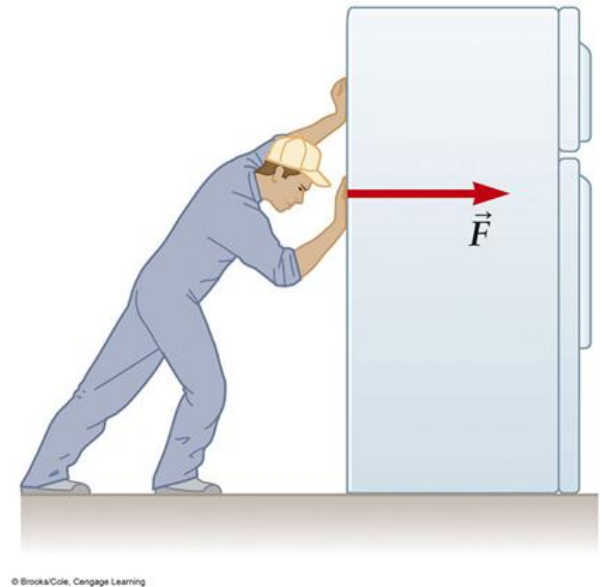

Demo: Static vs. kinetic friction

Friction, Summary

Static:

$$F_f (\text{max}) = \mu_s N$$

Kinetic: $F_f = \mu_k N$

Warning: N is sometimes equal to mg , but not always!

TABLE 4.2

Coefficients of Friction^a

	μ_s	μ_k
Steel on steel	0.74	0.57
Aluminum on steel	0.61	0.47
Copper on steel	0.53	0.36
Rubber on concrete	1.0	0.8
Wood on wood	0.25–0.5	0.2
Glass on glass	0.94	0.4
Waxed wood on wet snow	0.14	0.1
Waxed wood on dry snow	—	0.04
Metal on metal (lubricated)	0.15	0.06
Ice on ice	0.1	0.03
Teflon on Teflon	0.04	0.04
Synovial joints in humans	0.01	0.003

skidding

^aAll values are approximate.

© 2006 Brooks/Cole - Thomson

Worked Problem

Mary pulls a box of books with mass 25 kg to the right with a rope.

$$\mu_s = 0.5 \quad \mu_k = 0.3 \quad (\text{Use } g = 10 \text{ m/s}^2)$$

a. First she pulls horizontally on the box with a force of 40 N. The box doesn't move. What is the frictional force of the floor on the box?

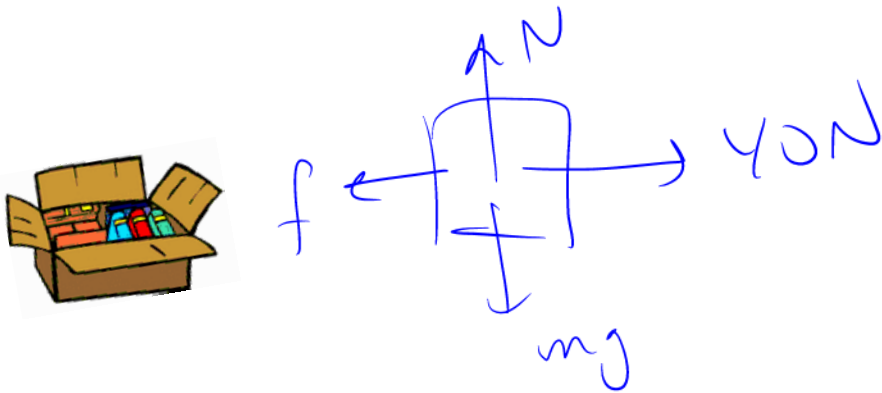

$$\sum F_x = ma_x = 0$$

$$40 - f = 0$$

$$f = 40 \text{ N}$$

b. What minimum force will she have to exert to get it moving?

$$\begin{aligned} f_{\max} &= \mu_s N \\ &= (0.5)(25)(10) \\ &= 125 \text{ N} \end{aligned}$$

$$\begin{aligned} \sum F_y &= ma_y = 0 \\ N - mg &= 0 \\ N &= mg \end{aligned}$$

Answers: 40N, 125 N

$$m = 25 \text{ kg}$$

$$\mu_s = .5$$
$$\mu_k = .3$$

$$F_m = 40 \text{ N}$$

Clicker quiz

If she pulls with force 175 N, what will the acceleration be after it starts moving?

a. 1 m/s^2

c. 4 m/s^2

b. 2 m/s^2

d. 6 m/s^2

e. $> 6 \text{ m/s}^2$

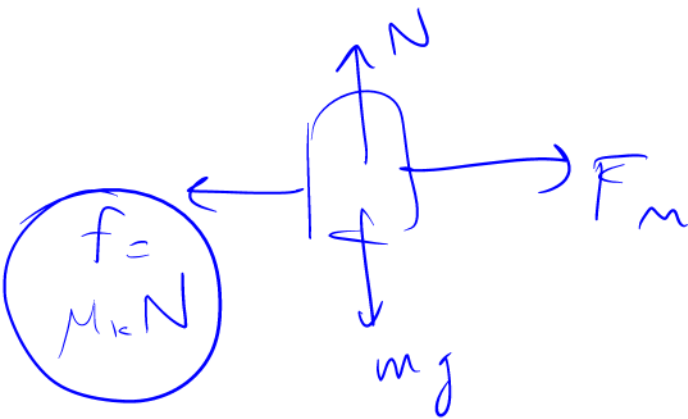

$$\frac{N}{mg}$$

$$\sum F_x = m a_x$$

$$\frac{F_m - \mu_k N}{m} = a_x$$

$$a_x = \frac{175 - (.3)(25)(10)}{25}$$

$$= 4 \text{ m/s}^2$$

Dr Colton's Guide:

How to solve Newton's 2nd Law Problems

1. Draw free-body diagrams for each object.
 - 1b. Divide forces into components if necessary.
 - 1c. Group objects together if it seems convenient.

2. Use the Newton's 2nd Law "blueprint equation" to get a "real equation" for each object.
 - 2b. Do this for both x- and y-directions if necessary.

3. Plug what you know into the equations, and look at what results.
 - 3b. Don't forget to plug in the acceleration, if it's known.

4. Solve the equations for what you're looking for.
 - 4b. Sometimes this involves solving simultaneous eqns.

Worked Problem

If Mary pulls the 25 kg box with force 230 N at an angle of 60° above the horizontal, what will the acceleration be? ($\mu_k = 0.3$)

FBD:



N2 for x:

N2 for y:

Plug what you know into the equations:

Solve the equations for what you're looking for:

Answers: $N = 50.8 \text{ N}$, $a = 3.99 \text{ m/s}^2$

Question

The tires on a 5000 kg truck have $\mu_s = 1.0$, $\mu_k = 0.8$ (tire to road friction)

What is the maximum stopping acceleration (negative)?

What is the maximum stopping acceleration **if the wheels are locked?**

→ What do anti-lock brakes do?

Answers: $1.0g \approx 10 \text{ m/s}^2$, $0.8g \approx 8 \text{ m/s}^2$

Friction on slopes

Clicker quiz: For the same skis and snow, as the slope angle **increases**, the ski/snow **kinetic frictional force**

- a. increases
- b. decreases
- c. stays the same

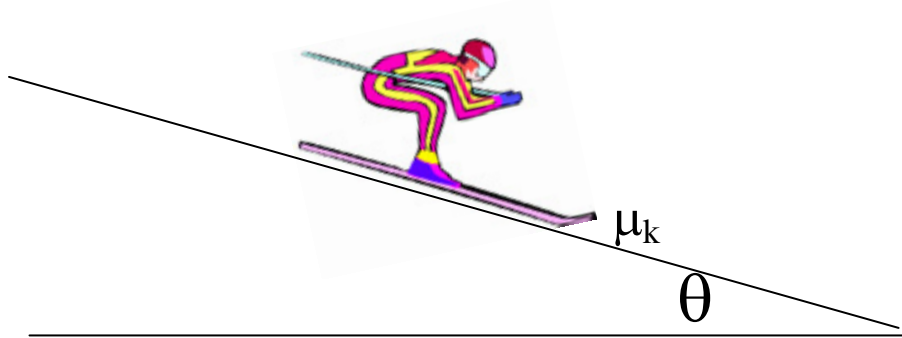

Hint: Man with mass m : what is his frictional force on a slope? Use N_2 .

From warmup

You start to push against a refrigerator. It initially does not budge, but then after you push hard enough it starts sliding along the floor. Which is correct?

- The friction force was smallest just after the refrigerator started to move.
- The friction force was largest just after the refrigerator started to move.
- The friction force was largest just before the refrigerator started to move.
- The friction force was constant the whole time.

A block is sliding down a ramp with constant speed. There is friction between the block and the ramp. The friction force is:

- smaller than the component of gravity down the ramp
- larger than the component of gravity down the ramp
- equal to the component of gravity down the ramp

From warmup

A small block is "riding" on top of a large block, which is being pulled to the right with a rope. Both blocks accelerate at the same rate to the right. The force of friction acting on the small block is:

- a. to the left
- b. to the right
- c. nonexistent

Demo: adjustable ramp

Demo Problem: a block on a ramp doesn't slide until the angle is _____^o from horizontal. What is μ_s ?

Demo Problem: Once the block starts to slide at that angle, it takes _____ s to slide down the _____ m of the ramp. What is μ_k ?

Worked Problem: You invent a new Olympic sport called pulley ski jumping. If the kinetic coefficient of friction is μ , what is your acceleration going up the hill in terms of all the other variables?

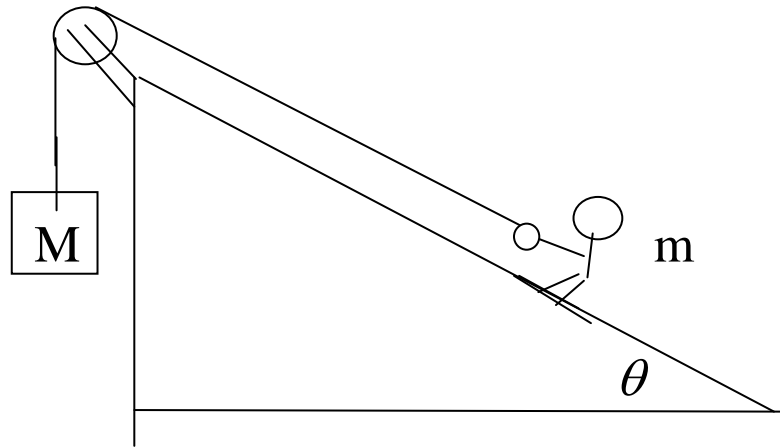

N2 for x:

N2 for y:

Plug what you know into the equations:

Solve the equations for what you're looking for:

Could you figure this out: How far does the jumper travel?