

Announcements – 23 Sep 2014

1. After today, just one more lecture of new material before Exam 1!!
 - a. Exam 1: Oct 2 – Oct 7 (2 pm) in the Testing Center, late fee after Oct 6 2 pm
 - b. Exam review sessions by Jerika: Wed Oct 1, 7 - 8:30 pm and Thurs Oct 2, 6 - 7:30 pm, both in room C295 ESC

2. **Newton's 2nd Law Problems:** $\sum \vec{F} = m\vec{a}$

- a. Forces: Inclined planes, Pulleys, Ropes, Friction, Etc.
- b. Accelerations: sometimes zero

→ Remember **N2 is a blueprint** for obtaining a useful equation; it's not the final equation itself.

The “ $\sum F$ ” on the left hand side means you have to consider all of the forces from your FBD and include them on the left hand side.

Do not put any forces on the right hand side!

“Which of the problems from last night's HW assignment would you most like me to discuss in class today?”

Inclined planes!

(another of the “simple machines”)



From warmup (last time): A skier is on a hill with no friction and a 20° slope. What is her acceleration?

- a. Less than 9.8 m/s^2
- b. Equal to 9.8 m/s^2
- c. More than 9.8 m/s^2

Question

What is her *precise* acceleration? (if no friction, no other forces)

$$W = mg$$

The standard technique: tilt the axes

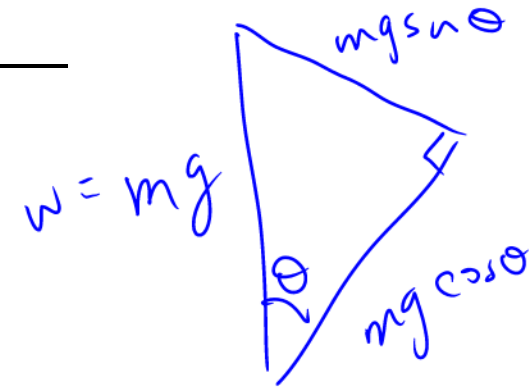
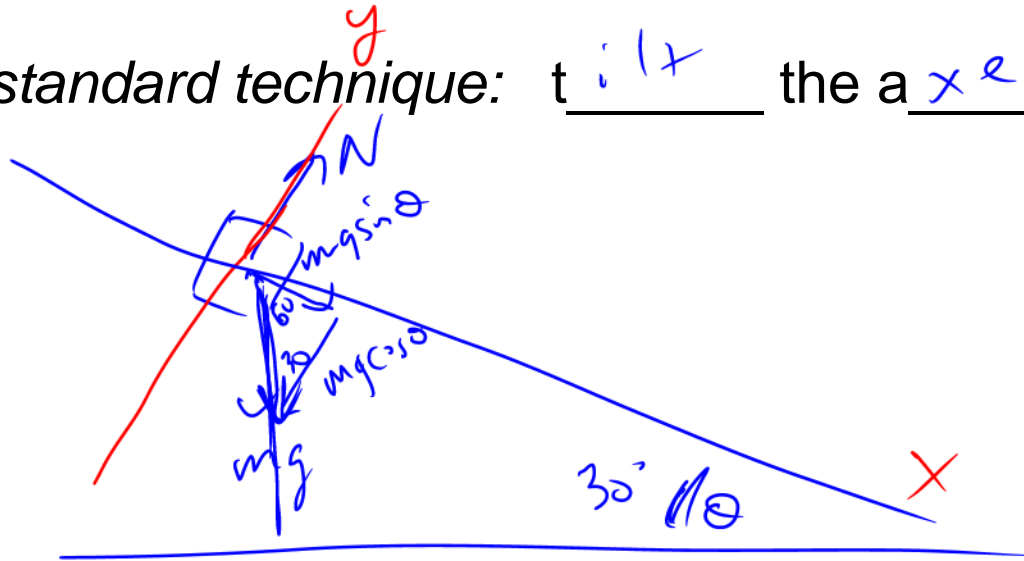

$$\sum F_x = ma_x$$

$$mg \sin \theta = ma_x$$

Hint: think of her acceleration for two extremes:
level ground
infinite slope

$$a = 9.8 \sin 20^\circ$$

$$\sum F_y = ma_y = 0$$

$$N - mg \cos \theta = 0$$

$$N = mg \cos \theta$$

Worked Problem

You push with a force of 200 N on a 25 kg frictionless ice block which is on a hill sloping 30° above the horizontal. What is the acceleration of the block? Use $g = 10 \text{ m/s}^2$.

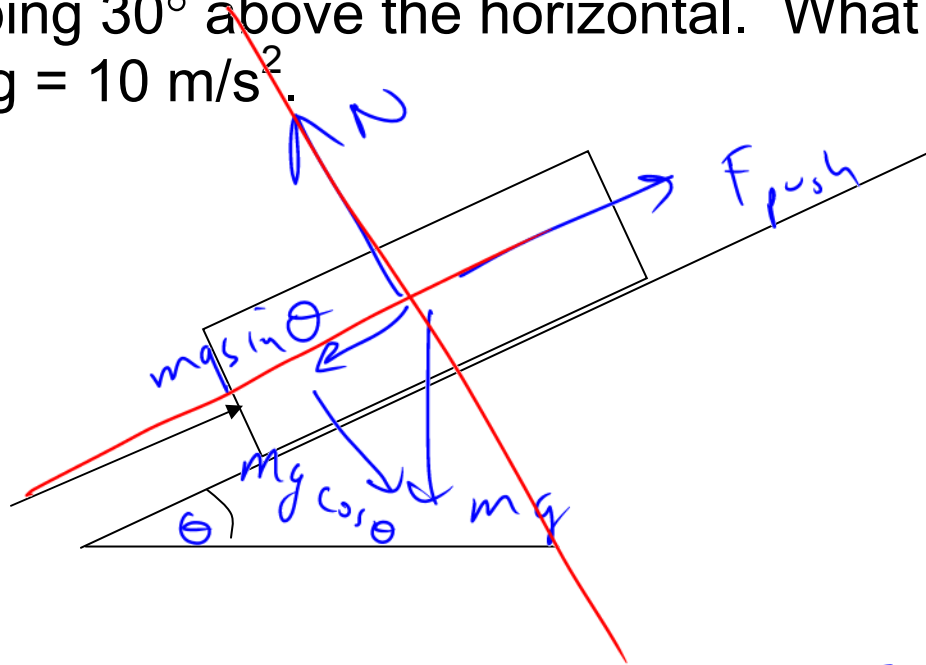

$$\sum F_x = ma_x$$

$$\sum F_x = ma_x$$
$$F_{\text{push}} - mg \sin \theta = ma$$

$$a = \frac{F_{\text{push}} - mg \sin \theta}{m}$$

Answer: 3.0 m/s^2

$$\sum F_y = ma_y$$

$$N - mg \cos \theta = 0$$

$$200 \text{ N} - (25 \text{ kg})(10 \text{ m/s}^2) \sin 30^\circ$$
$$25 \text{ kg}$$

$$= 3 \text{ m/s}^2$$

Clicker quiz

Which box is easier to get moving? (same box, same F , friction is present)

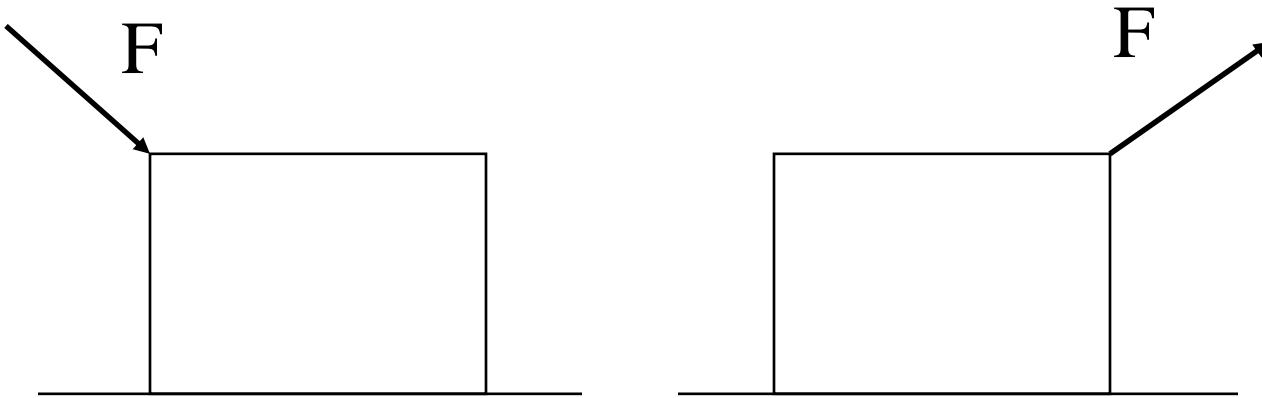

- a. left is easier
- b. right is easier
- c. same

Why?

Friction depends on the Normal force

Friction depends on whether it's already "sliding"

Book figure:

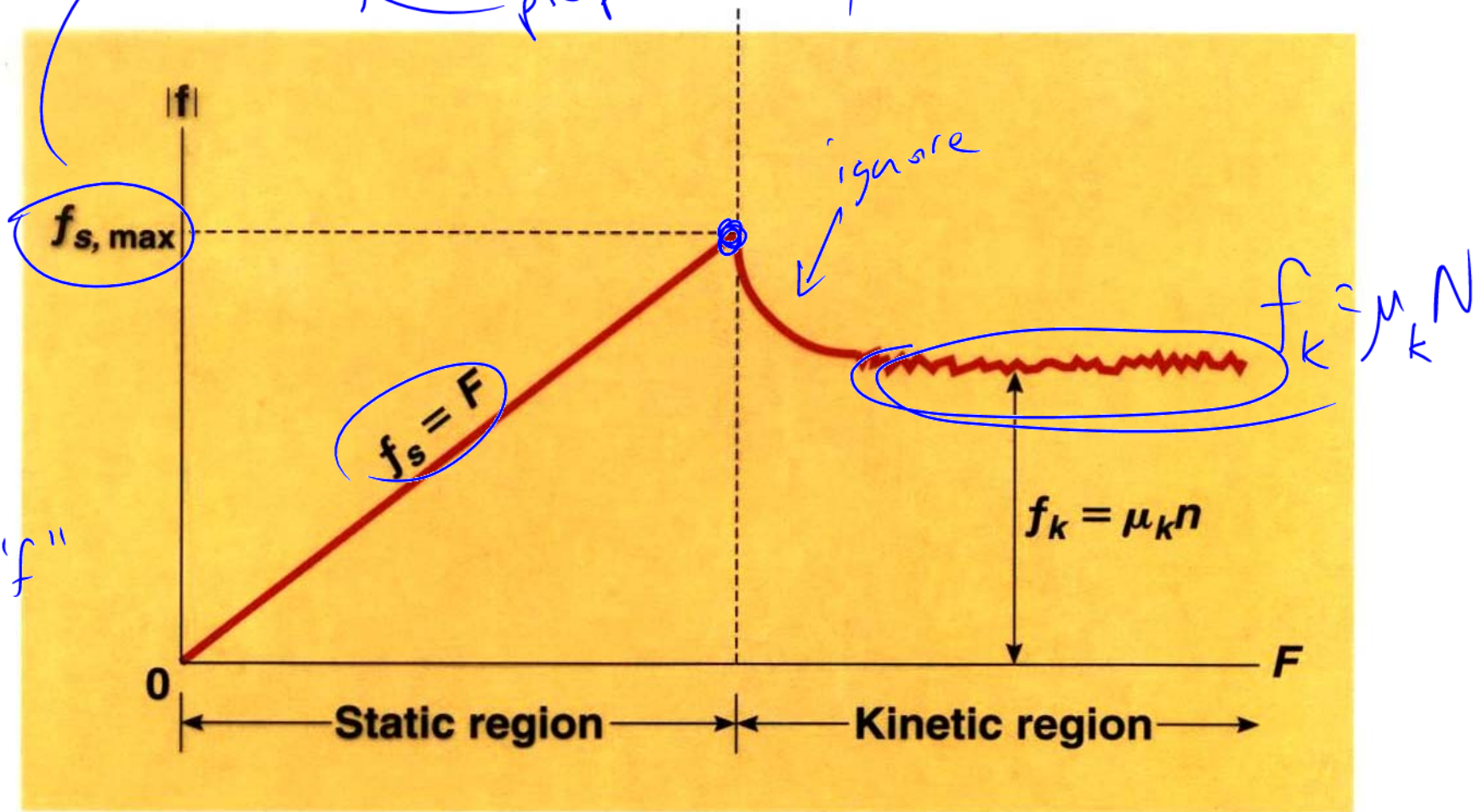

$F_{\text{friction}} = "f"$

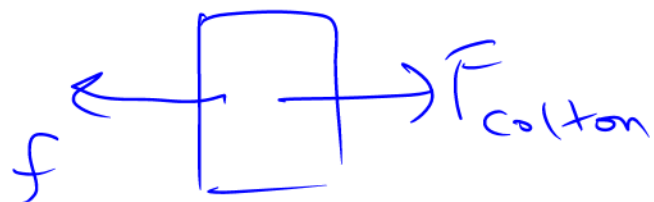

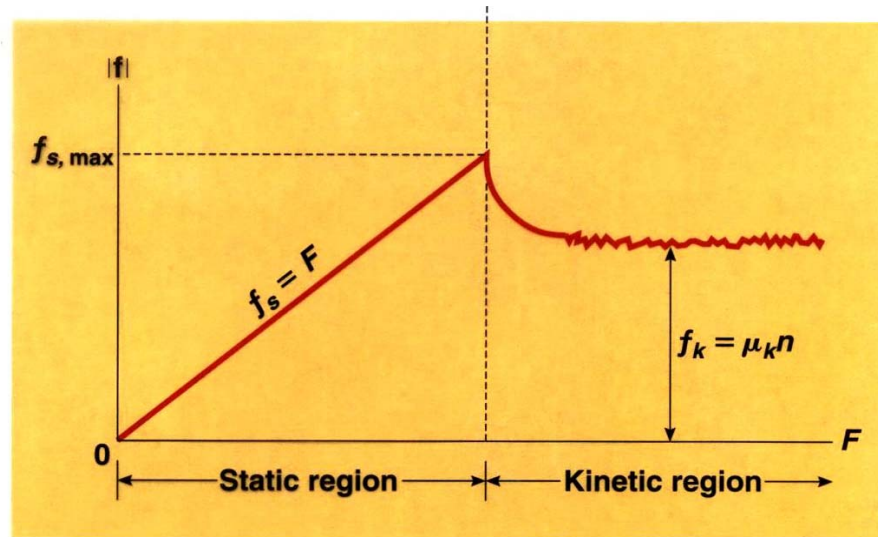

Compare with the forces when you pull & snap a rope tied to a wall.
 What is the tension in the rope?

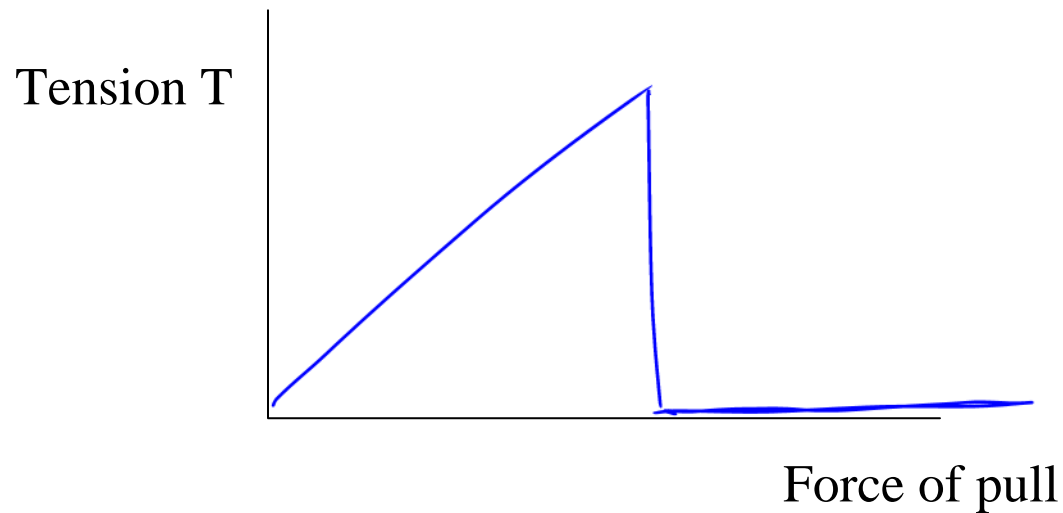

Kinetic Friction

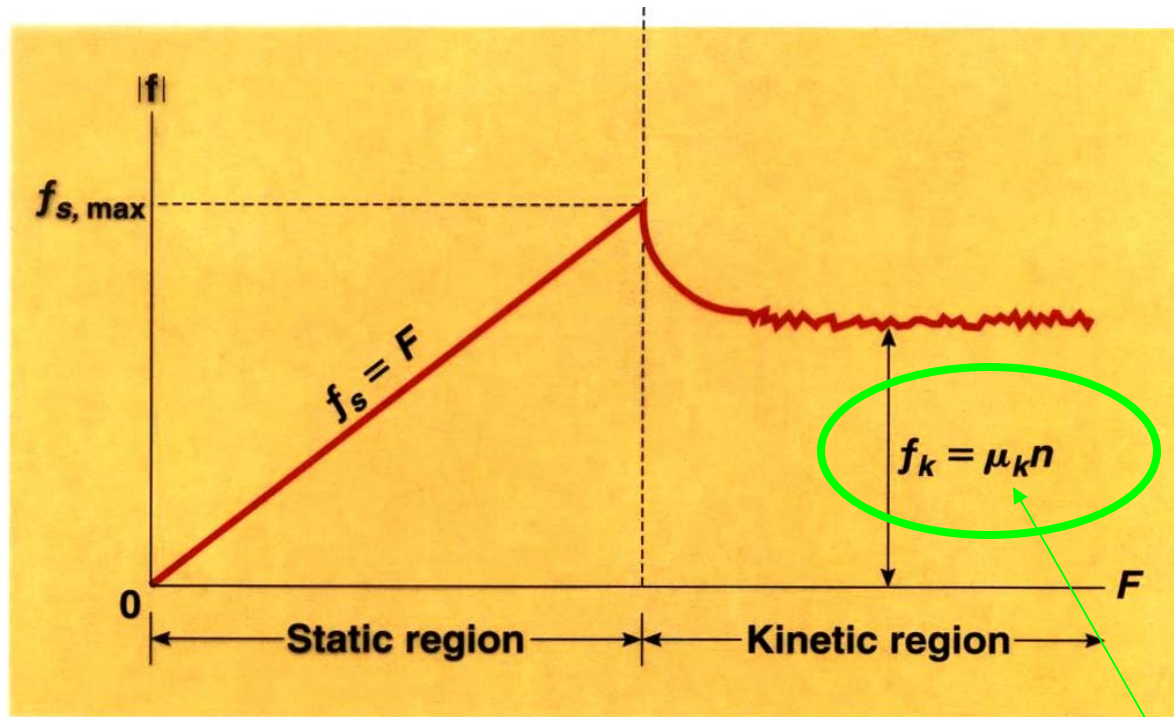

μ = "coefficient of friction"

From warmup

$$f_s \leq \mu_s N$$

$$f_k = \mu_k N$$

Ralph noticed that in the equation for the force of static friction, there's a "less than or equal to" sign, but in the equation for kinetic friction, there is a plain equals sign. He wants to know why they are different. What should I tell him?

“Think-pair-share”

- Think about it for a bit
- Talk to your neighbor, find out if he/she thinks the same as you
- Be prepared to share your answer with the class if called on

Clicker: I am now ready to share my answer if randomly selected.

a. Yes

Note: you are allowed to "pass" if you would really not answer.

Static Friction

Grows with sideways force, to a point....

Before slipping pt:

Friction force is increasing

At slipping pt:

Friction force is maximum

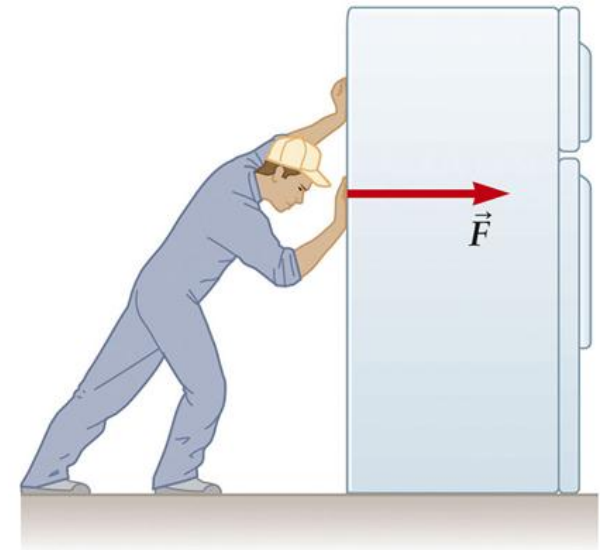

© Brooks/Cole, Cengage Learning

Demo: Static vs. kinetic friction

Friction, Summary

Static:

$$F_f (\text{max}) = \mu_s N$$

Kinetic: $F_f = \mu_k N$

Warning: N is sometimes equal to mg , but not always!

TABLE 4.2

Coefficients of Friction^a

	μ_s	μ_k
Steel on steel	0.74	0.57
Aluminum on steel	0.61	0.47
Copper on steel	0.53	0.36
Rubber on concrete	1.0	0.8
Wood on wood	0.25–0.5	0.2
Glass on glass	0.94	0.4
Waxed wood on wet snow	0.14	0.1
Waxed wood on dry snow	—	0.04
Metal on metal (lubricated)	0.15	0.06
Ice on ice	0.1	0.03
Teflon on Teflon	0.04	0.04
Synovial joints in humans	0.01	0.003

^aAll values are approximate.

© 2006 Brooks/Cole - Thomson

Worked Problem

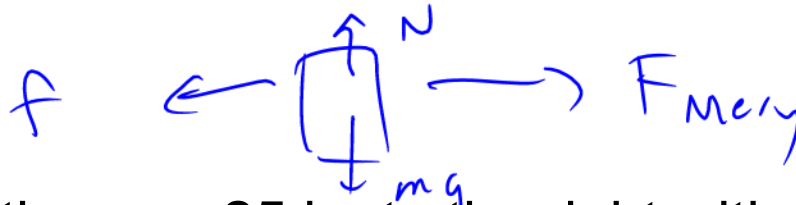

Mary pulls a box of books with mass 25 kg to the right with a rope.

$$\mu_s = 0.5 \quad \mu_k = 0.3 \quad (\text{Use } g = 10 \text{ m/s}^2)$$

a. First she pulls horizontally on the box with a force of 40 N. The box doesn't move. What is the frictional force of the floor on the box?



$$\sum F_x = ma_x$$

$$F_{\text{Mary}} - f = 0$$

$$f = F_{\text{Mary}}$$

$$40 \text{ N}$$

b. What minimum force will she have to exert to get it moving?

$$\sum F_x = ma_x$$

$$F_{\text{Mary}} - f_{\text{max}} = 0$$

$$F_{\text{Mary}} = f_{\text{max}}$$

$$\sum F_y = ma_y = 0$$

$$N = mg$$

Answers: 40N, 125 N

$$f_{\text{max}} = \mu_s N = (0.5)(25 \text{ kg})(10 \text{ m/s}^2)$$

$$= 125 \text{ N}$$

Clicker quiz

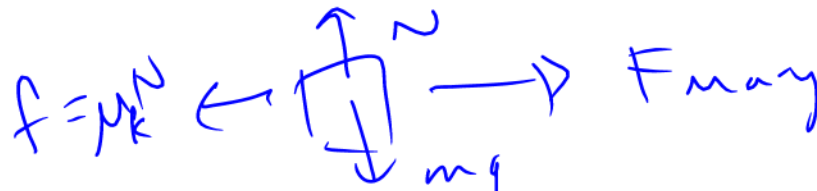

Mary pulls a box of books with mass 25 kg to the right with a rope.

$$\mu_s = 0.5 \quad \mu_k = 0.3 \quad (\text{Use } g = 10 \text{ m/s}^2)$$

If she pulls with force 175 N, what will the acceleration be after it starts moving?

- a. 1 m/s²
- b. 2 m/s²
- c. 4 m/s²
- d. 6 m/s²
- e. > 6 m/s²

$$\sum F_x = ma_x$$

$$F_{\text{Mary}} - \mu_k N = ma$$

$$\sum F_y = ma_y = 0$$

$$N - mg = 0$$

$$N = mg$$

$$175 \text{ N} - (0.3)(25 \text{ kg})(10 \text{ m/s}^2) = (25 \text{ kg})a$$

$$a = \frac{175 - 75}{25} = 4 \text{ m/s}^2$$

Dr Colton's Guide:

How to solve Newton's 2nd Law Problems

1. Draw free-body diagrams for each object.
 - 1b. Divide forces into components if necessary.
 - 1c. Group objects together if it seems convenient.

2. Use the Newton's 2nd Law "blueprint equation" to get a "real equation" for each object.
 - 2b. Do this for both x- and y-directions if necessary.

3. Plug what you know into the equations, and look at what results.
 - 3b. Don't forget to plug in the acceleration, if it's known.

4. Solve the equations for what you're looking for.
 - 4b. Sometimes this involves solving simultaneous eqns.

Worked Problem

If Mary pulls the 25 kg box with force 230 N at an angle of 60° above the horizontal, what will the acceleration be? ($\mu_k = 0.3$)

$a = 1.0 \text{ m/s}^2$

FBD:

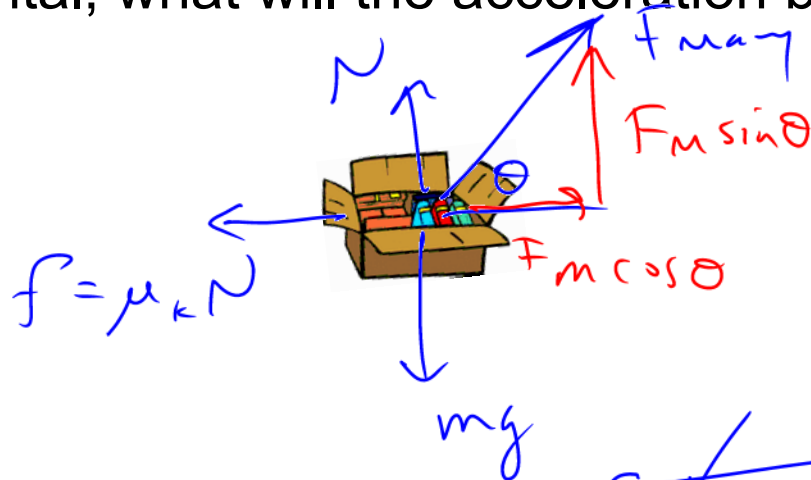

N2 for x: $\sum F_x = ma_x$

$$F_M \cos \theta - \mu_k N = ma$$

N2 for y: $\sum F_y = ma_y = 0$

$$N + F_M \sin \theta - mg = 0$$

Plug what you know into the equations:

$$\begin{aligned} N &= mg - F_M \sin \theta \\ &= (25)(10) - (230) \sin 60^\circ \\ &= \boxed{50.8 \text{ N}} \end{aligned}$$

Solve the equations for what you're looking for:

Answers: $N = 50.8 \text{ N}$, $a = 3.99 \text{ m/s}^2$

Question

The tires on a 5000 kg truck have $\mu_s = 1.0$, $\mu_k = 0.8$ (tire to road friction)

What is the maximum stopping acceleration (negative)?

What is the maximum stopping acceleration **if the wheels are locked?**

→ What do anti-lock brakes do?

Answers: $1.0g \approx 10 \text{ m/s}^2$, $0.8g \approx 8 \text{ m/s}^2$

Friction on slopes

Clicker quiz: For the same skis and snow, as the slope angle **increases**, the (kinetic) **frictional force**

- a. increases
- b. decreases
- c. stays the same

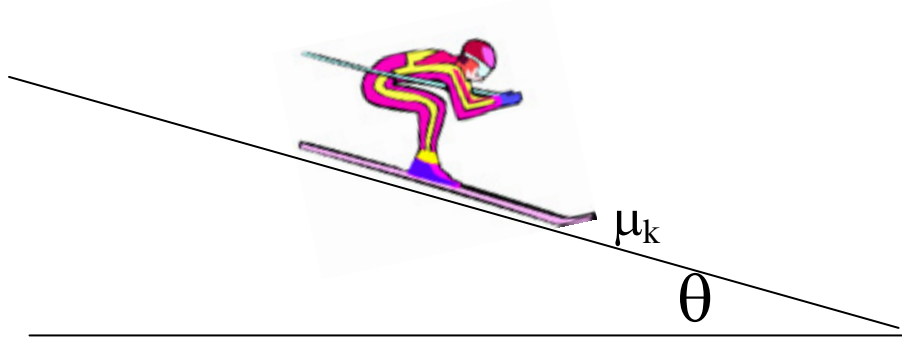

Hint: Man with mass m : what is his frictional force on a slope? Use N_2 .

From warmup

You start to push against a refrigerator. It initially does not budge, but then after you push hard enough it starts sliding along the floor. Which is correct?

- The friction force was smallest just after the refrigerator started to move.
- The friction force was largest just after the refrigerator started to move.
- The friction force was largest just before the refrigerator started to move.
- The friction force was constant the whole time.

A block is sliding down a ramp with constant speed. There is friction between the block and the ramp. The friction force is:

- smaller than the component of gravity down the ramp
- larger than the component of gravity down the ramp
- equal to the component of gravity down the ramp

From warmup

A small block is "riding" on top of a large block, which is being pulled to the right with a rope. Both blocks accelerate at the same rate to the right. The force of friction acting on the small block is:

- a. to the left
- b. to the right
- c. nonexistent

Demo: adjustable ramp

Demo Problem: a block on a ramp doesn't slide until the angle is _____[°] from horizontal. What is μ_s ?

Demo Problem: Once the block starts to slide at that angle, it takes _____ s to slide down the _____ m of the ramp. What is μ_k ?

Worked Problem: You invent a new Olympic sport called pulley ski jumping. If the kinetic coefficient of friction is μ , what is your acceleration going up the hill in terms of all the other variables?

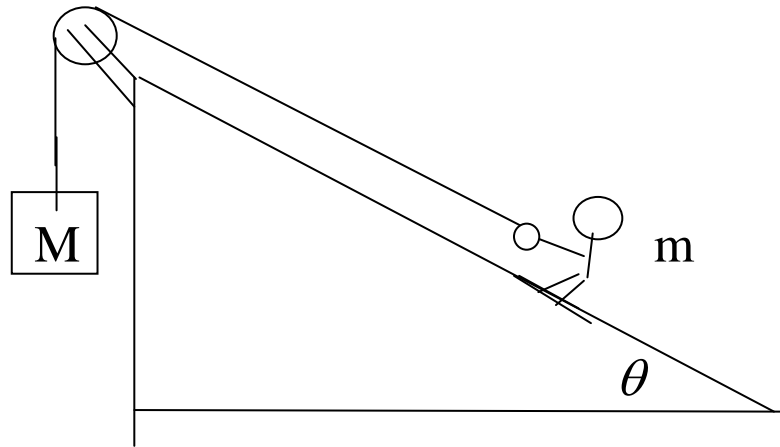

N2 for "x", combined:

N2 for y:

Plug what you know into the equations:

Solve the equations for what you're looking for:

$$\text{Answer: } a = \frac{Mg - mg \sin \theta - \mu mg \cos \theta}{M + m}$$

Accelerating Reference Frames

Demo: Rotating chair, Ball on string

To be able to ascribe accelerations to *real* forces, you must be observing the motion from a **non-accelerating (constant velocity) point of view**

Physics lingo: “point of view” = “reference frame”

Amusement Park Ride: Circular room spins, floor drops out. What are the forces on you?

Fictitious Forces

In **accelerating** reference frames, we tend to invent **fictitious forces**.

Other examples: Coriolis force, car hits brakes

Clicker quiz

A car hits a large icy spot on the road at point P. What is the path of the car if there is no friction on the ice?

